

CHEM-FEED[®]

Municipal Skid Systems



Series CFWS

1.0	Introduction	4
<hr/>		
2.0	Features	4
<hr/>		
3.0	Specifications	5
<hr/>		
4.0	Dimensions	6
<hr/>		
5.0	Mounting a pump to the system	8
<hr/>		
6.0	Mounting the skid system to wall	8
<hr/>		
7.0	Component Identification and Typical Operation - Simplex Skid	9
<hr/>		
	7.1 How to Operate the Chem-Feed® Skid System - Simplex Skid	10
<hr/>		
8.0	Component Identification and Typical Operation - Duplex Skid	11
<hr/>		
	8.1 How to operate the Chem-Feed Skid System - Duplex Skid	12
<hr/>		
9.0	Chem-Feed® Skid System Matrix	13
<hr/>		
10.0	Warranty	15
<hr/>		

READ THE INSTRUCTION MANUAL PRIOR TO INSTALLATION AND USE.



+1 (714) 893 - 8529



sales@blue-white.com



customerservice@blue-white.com



5300 Business Drive
Huntington Beach, CA 92649

1.0 Introduction

Congratulations on purchasing the Chem-Feed® Engineered Wall Skid System. The system is designed with the necessary components to safely inject liquid chemical into a system.

Your Chem-Feed® Engineered Wall Skid System is pre-configured based on your selections via the matrix or when designed with our engineering staff.

Please Note: Your new Chem-Feed® System has been pressure tested at the factory with clean water for a minimum of four hours before shipping. You may notice trace amounts of clean water in the system. This is part of our stringent quality assurance program at Blue-White Industries



CAUTION. Skid is provided only for the application and use for which it is intended. User assumes responsibility for proper operation and maintenance. User is responsible for ensuring skid components are compatible with the chemicals being used. Contact the factory if there are any questions regarding use or compatibility.

2.0 Features

Chem-Feed® Engineered Skid Systems were designed and engineered using solid modeling tools for superior piping installation and easy component maintenance. Custom engineered universal mounting blocks and pre-machined mounting slots provide for easy component servicing and replacement. Each factory built and tested system includes the following standard components:

- **Pressure Relief Valve** - Protects the system from over-pressurization, 5-150 psi setting range, 150 psi maximum system pressure. Ships on all systems.
- **Check Valve** - Protects the user from back-flow during pump maintenance. Ships on all systems.
- **Flow Verification Sensor** - MS6 accurately verifies chemical feed. Exclusive to Blue-White®. Optional.
- **Inlet Y Strainer** - Protects system components from damage cause by dirt or debris. Ships on all systems.
- **Calibration Cylinder** - Confirm pump output under system conditions. Specify cylinder volumes from 3 GPH to 128 GPH. Optional.
- **Pulsation Dampener** - Protect the system components from pulsation. Recommended for diaphragm pump systems. Not recommended for peristaltic pump systems. Optional.
- **Pressure Gauge with Guard** - Isolate and protect the system pressure gauge. Specify pressure ranges from 0-30 psi, 0-100 psi, or 0-200 psi. Optional
- **Strut Mounts** - FRP Strut is provided with the skid to ensure sturdy support for wall mounting. Ships will all systems.
- **Corrosion Resistant** - Chem-Feed® frame constructed of chemically resistant polyethylene.
- **Pump Mount Bracket** - Constructed of chemically resistant polyethylene. Ships with all systems.

3.0 Specifications

Items listed below are standard available items and ship with most configurations. Your system may be customized with components not listed below.

Skid	Chemically resistant polyethylene structure
Pump (sold separately)	FLEXFLO® M1, M2, M3 or M4 peristaltic pumps CHEM-FEED® MD1, C2, C3 or MD3 diaphragm pumps
Piping	1/2" PVC Schedule 80 (optional CPVC, PVDF, CHEM PROLINE®)
Seals	FKM seals (optional EPDM)
Tubing (T)	Reinforced braided PVC, 200 psi max, certified NSF 51 / NSF 61. The pump inlet and outlet flexible tubing connections are terminated to half unions and secured to the barbed fitting with stainless steel clamps. (Optional: 1/2" PTFE, 1/4" PE, 1/4" PTFE)
Tubing Clamps	300 series SS band, 400 series SS screw
Unions (U)	PVC body, schedule 80 (optional CPVC, PVDF)
Ball Valves (V)	True unions, Vented, PVC body, PTFE shaft bearings and seats (optional CPVC, PVDF)
Pressure Relief Valve (PRV)	PVC body, PTFE primary diaphragm seal. Non-wetted components: EPDM secondary seal, zinc plated steel spring, stainless steel external hardware, HDPE pressure adjustment screw. Infinite adjustment from 10-150 psi. (optional CPVC, PVDF)
Calibration Cylinder (CC)	PVC body, PVC end caps, 1/2" PVC pipe outlet vent. Available volumes: 3 GPH (100ml), 8 GPH (250ml), 16 GPH (500ml), 32 GPH (1000ml), 64 GPH (2000ml), and 128 GPH (4000mL). (Optional Glass)
Pulsation Dampener (PD)	CPVC body, 10 cubic inch volume (optional PVDF)
Gauge W/Guard (G)	Gauge: liquid filled stainless steel with blowout plug, bottom mount, 1/4" NPT threads. Available pressure ranges: 0-30 psi, 0-100, psi, 0-200 psi. Guard: PVC body, temperature compensated oil filled. (optional CPVC, PVDF)
Check Valve (CV)	PVC body. Cracking pressure: 1.0-1.5 psi Maximum working pressure: inlet = 150 psi, back = 100 psi (optional CPVC, PVDF)
Flow Sensor (MS6)	Available Flow Ranges: 10 - 5,000 ml/min, 100-10,000 ml/min
Y Strainer (S)	PVC body, 1/32" Mesh (optional CPVC, PVDF)
Pressure Switch (PSH)	316 Stainless Steel
Back-Pressure Valve (BPV)	PVC body, 0-150 PSI Range (optional CPVC, PVDF)
Universal Mounting Blocks	PA 12
Pump Mounting Brackets	316 Stainless Steel
Skid Mounting Strut	FRP
Mounting Hardware	304 Stainless Steel
Maximum Working Pressure	150 psig (10.3 bar)
Operating Temperature	14 °F to 115 °F (-10 °C to 46 °C)
Maximum Overall Dimensions	60" W x 48" H x 17.41" D (152.4W x 121.9H x 44.2D cm)
Skid Weight	80 lb. (Not including pumps)
Approximate Shipping Weight	280 lb. (127 kg) (Pumps ship separately)

4.0 Dimensions

Your Chem-Feed System may be designed differently from drawings below. However, the dimensions shown below remain the same no matter your configuration.

Simplex Pump System:

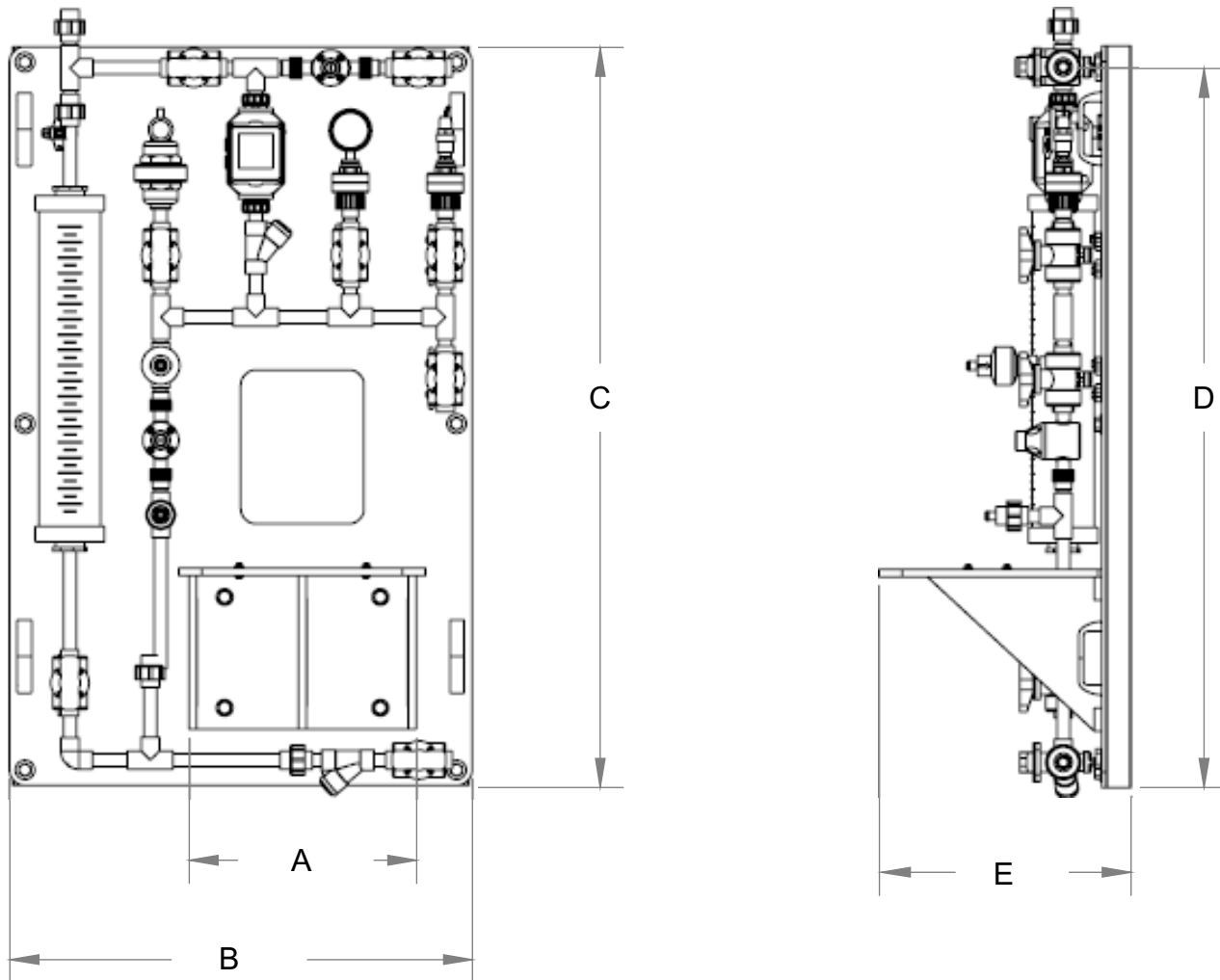

Dim	Inch	cm
A	14.75"	37.5
B	30.00"	76.2
C	48.00"	121.9

Dim	Inch	cm
D	46.63"	118.4
E	16.25"	41.3

Duplex Pump System:

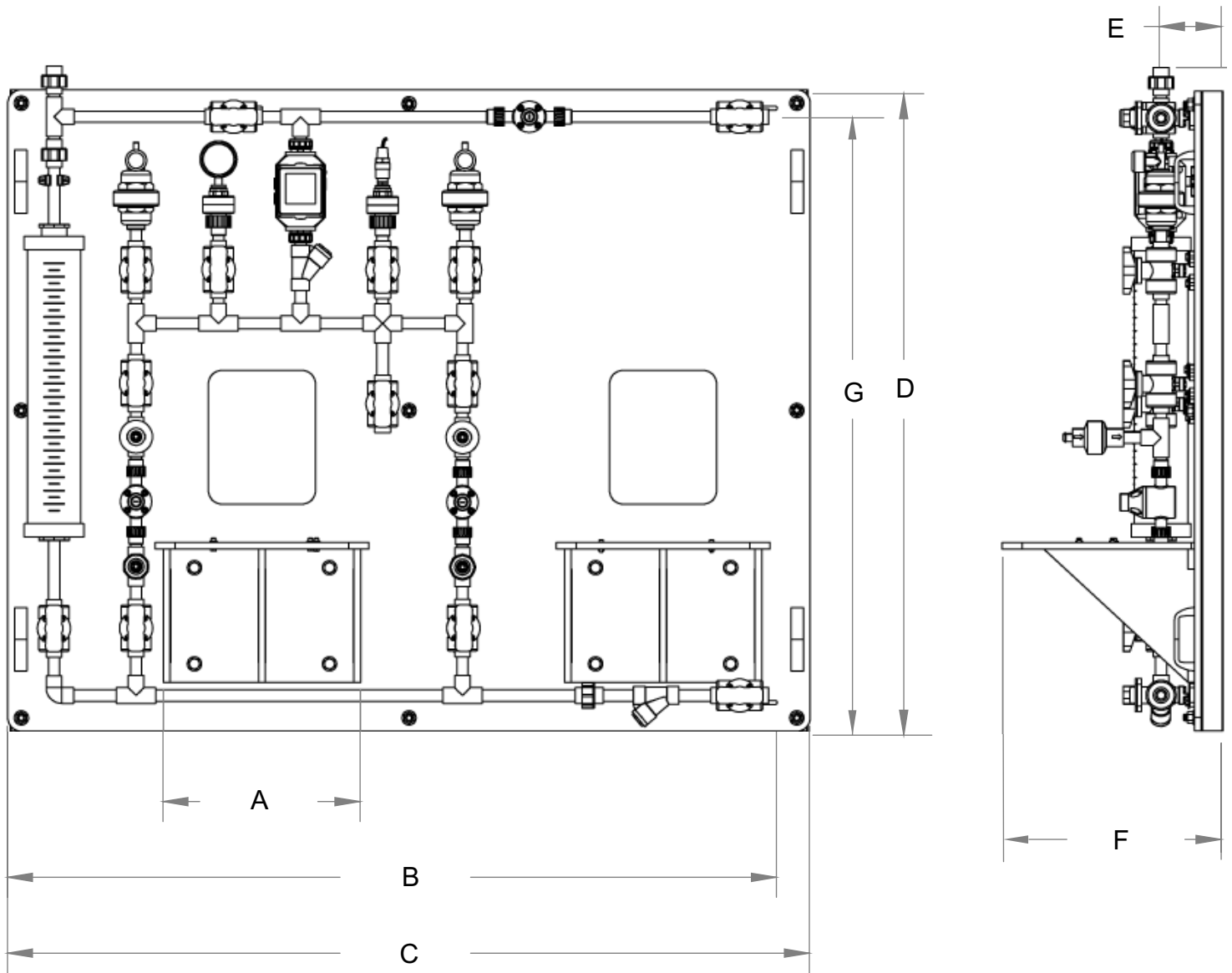

Dim	Inch	cm	Dim	Inch	cm
A	14.75"	37.5	E	4.63"	11.70
B	57.53"	146.1	F	16.50"	41.6
C	60.00"	152.4	G	46.63"	118.4
D	48.00"	121.9			

5.0 Mounting Pump to the Chem-Feed® System

Socket Head
Screw, SS #10-32 - .625"
#10 washer, and 10-32 nut.
(Qty: 4 of each per pump)

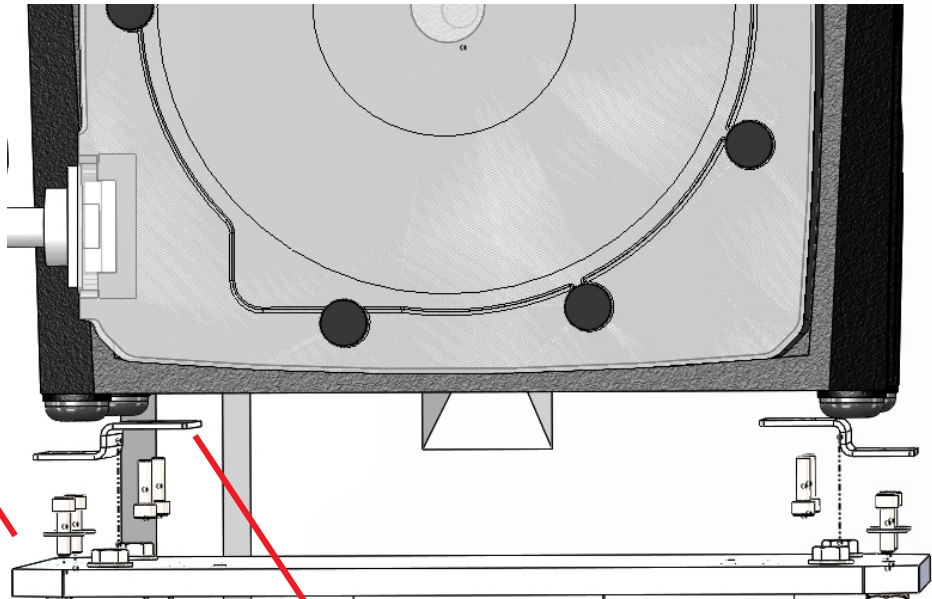

Mounting Bracket
(Qty: 2 per pump)

6.0 Mounting the Chem-Feed® System

1. Locate mounting position of skid on wall.
2. Use dimensions and strut to mark best location for wall anchors.
3. Remove strut from skid, and mount to wall with anchors.
4. Re-mount skid to strut.
5. Mount pump(s).

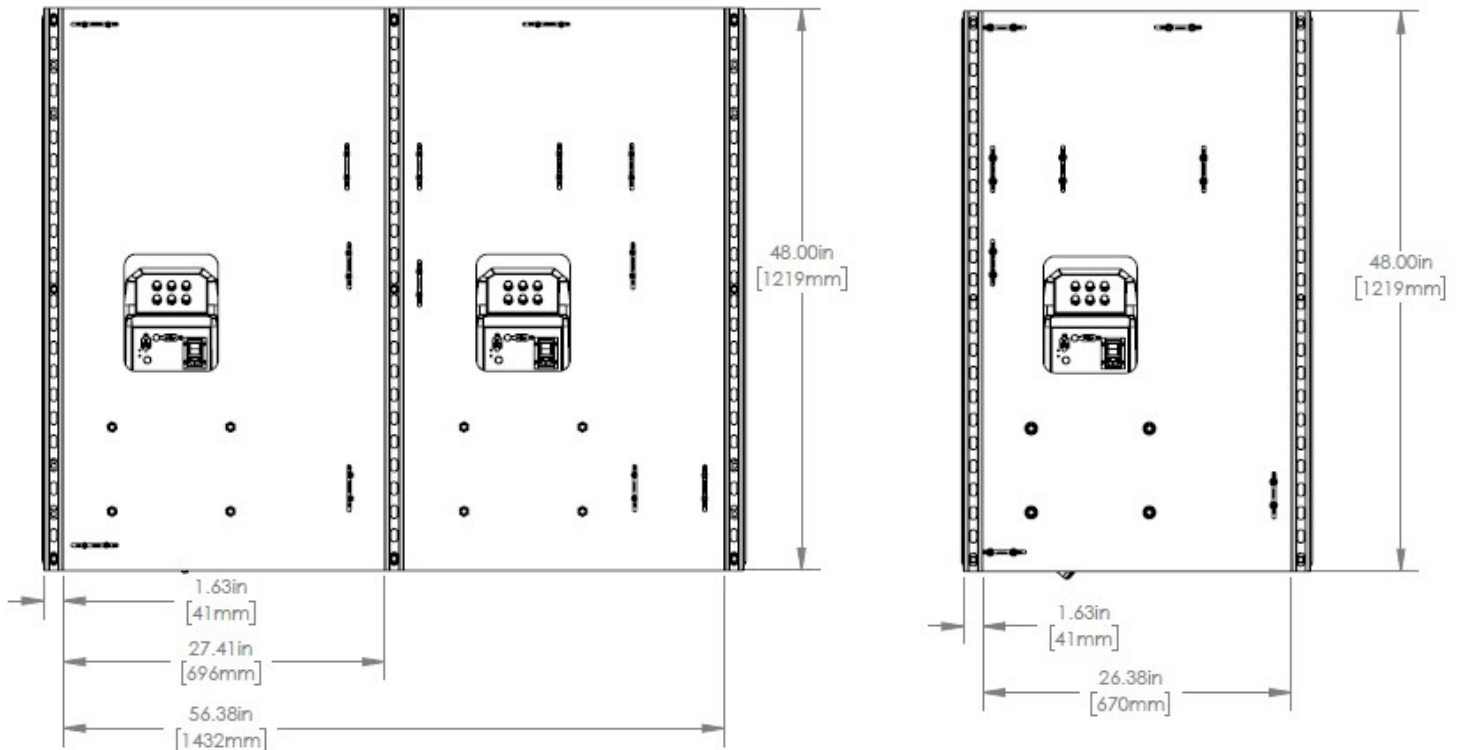

7.0 Component Identification and Typical Operation - Simplex Pump Skid

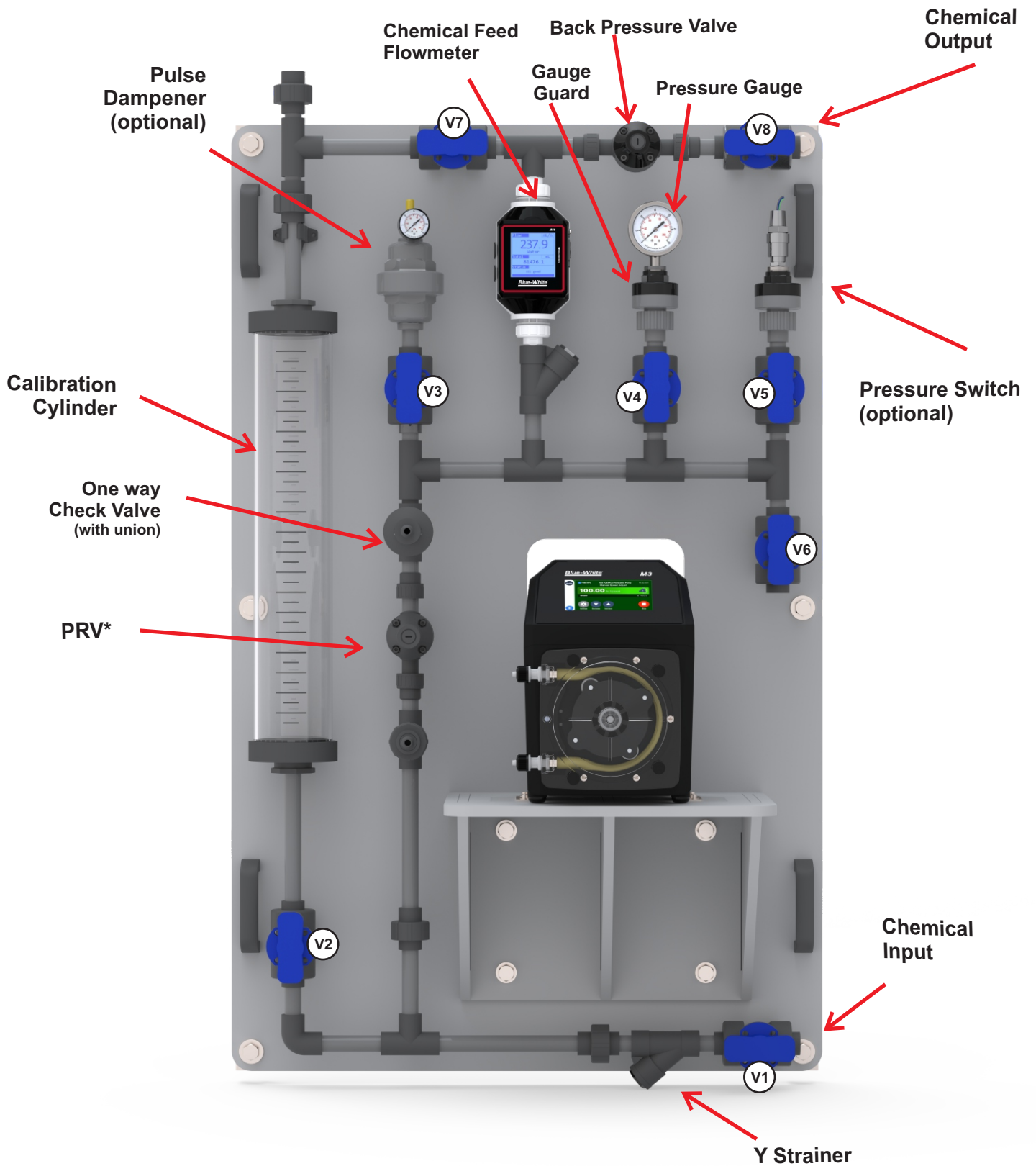

* PRV = Pressure Relief Valve preset at 50psi

7.1 How To Operate the Chem-Feed® Skid System - Simplex Pump Skid

Connections:

Connect chemical solution into chemical Inlet (V-1)

Connect chemical treated system to outlet. (V-8)

To Pump chemical solution into system.

Open ball valve V-1.

Open ball valve V-3, V-4, and V-5 (if optional equipment included).

Close ball valve V-2, V-6, and V-7.

Open ball valve V-8 to inject chemical solution into your system.

Start pump.

To calibrate pump / system.

Open ball valve V-1.

Open ball valve V-7.

Close ball valve V-2, V-6, and V-8.

Start pump and run until calibration cylinder is filled to top calibration line. Do not leave pump unattended during this operation.

Stop pump once calibration cylinder is filled.

Close ball valves V-1 and V-7.

Open ball valve V-2 and V-8 to inject chemical solution into your system.

Note the chemical solution level in the calibration cylinder.

To calibrate pump at maximum speed into your system, Press the prime button on pump. The prime mode runs the pump at maximum speed for 60 seconds (1 minute) on all Blue-White® pumps.

To calibrate pump at your desired feed rate, you must pre-program your pump speed before running this routine. Please refer to the instruction manual for your pump to adjust feed rate and additional calibration instructions.

Repeat process to ensure accuracy of calibration.

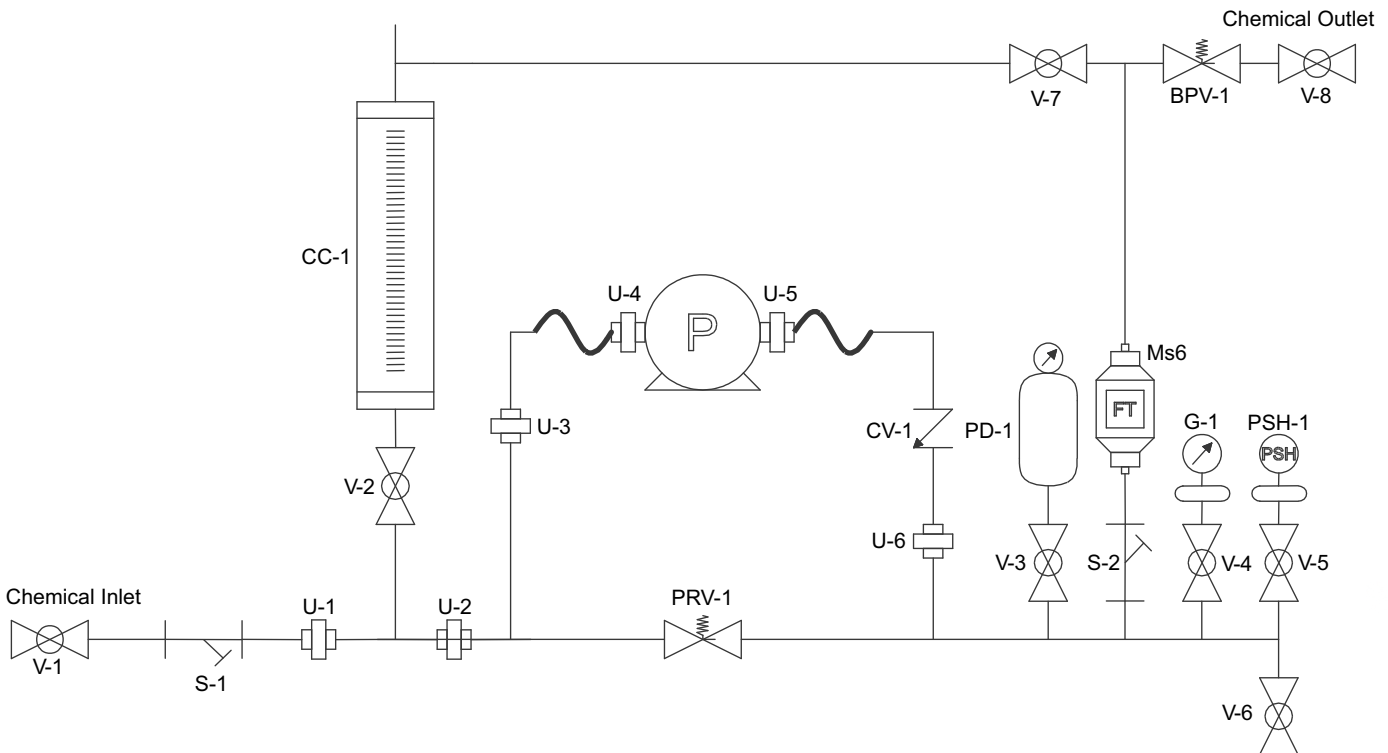

8.0 Component Identification and Typical Operation - Duplex Pump Skid System

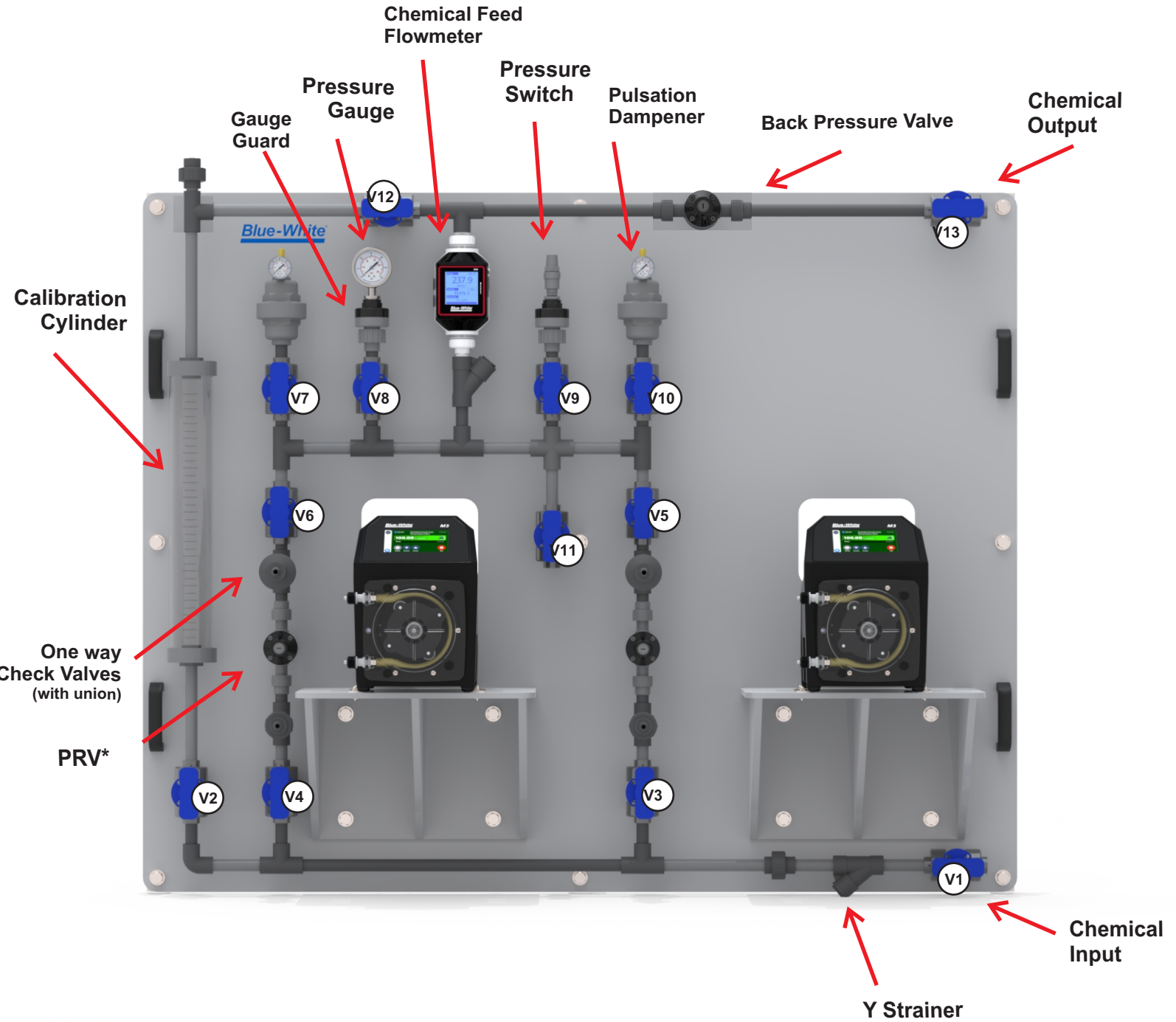

* PRV = Pressure Relief Valve preset at 50psi

8.1 How To Operate the Chem-Feed® Duplex Skid System

Connections:

Connect chemical solution into Inlet. (V-1)

Connect chemical treated system to outlet. (V-13)

To Pump chemical solution into system.

Open ball valve V-1.

Open ball valve V-3, or V-4, depending on which pump is being used.

Close ball valve V-2, V-11, and V-12.

Open ball valve V-5 or V-6, depending on your system design.

Open ball valve V-7, V-8, V-9, V-10 depending on your system design.

Open ball valve V-13 to inject chemical solution into your system.

Start pump(s).

To calibrate pump(s) / system.

Open ball valve V-1.

Open ball valve V-3 or V-4, depending on which pump is being calibrated.

Open ball valve V-5 or V-6, depending on which pump is being calibrated.

Close ball valve V-2, V-11, and V-13.

Open ball valve V-12. This open valve will direct chemical into calibration cylinder.

Start pump and run until calibration cylinder is filled to top calibration line. Do not leave pump unattended during this operation!

Stop pump once calibration cylinder is filled.

Close ball valves V-1 and V-12.

Open ball valve V-2 and V-13 to inject chemical solution into your system.

Note the chemical solution level in the calibration cylinder.

To calibrate pump at maximum speed into your system, Press the prime button on pump. The prime mode runs the pump at maximum speed for 60 seconds (1 minute) on all Blue-White® pumps.

To calibrate pump at your desired feed rate, you must pre-program your pump speed before running this routine. Please refer to the instruction manual for your pump to adjust feed rate and additional calibration instructions.

Repeat process to ensure accuracy of calibration.

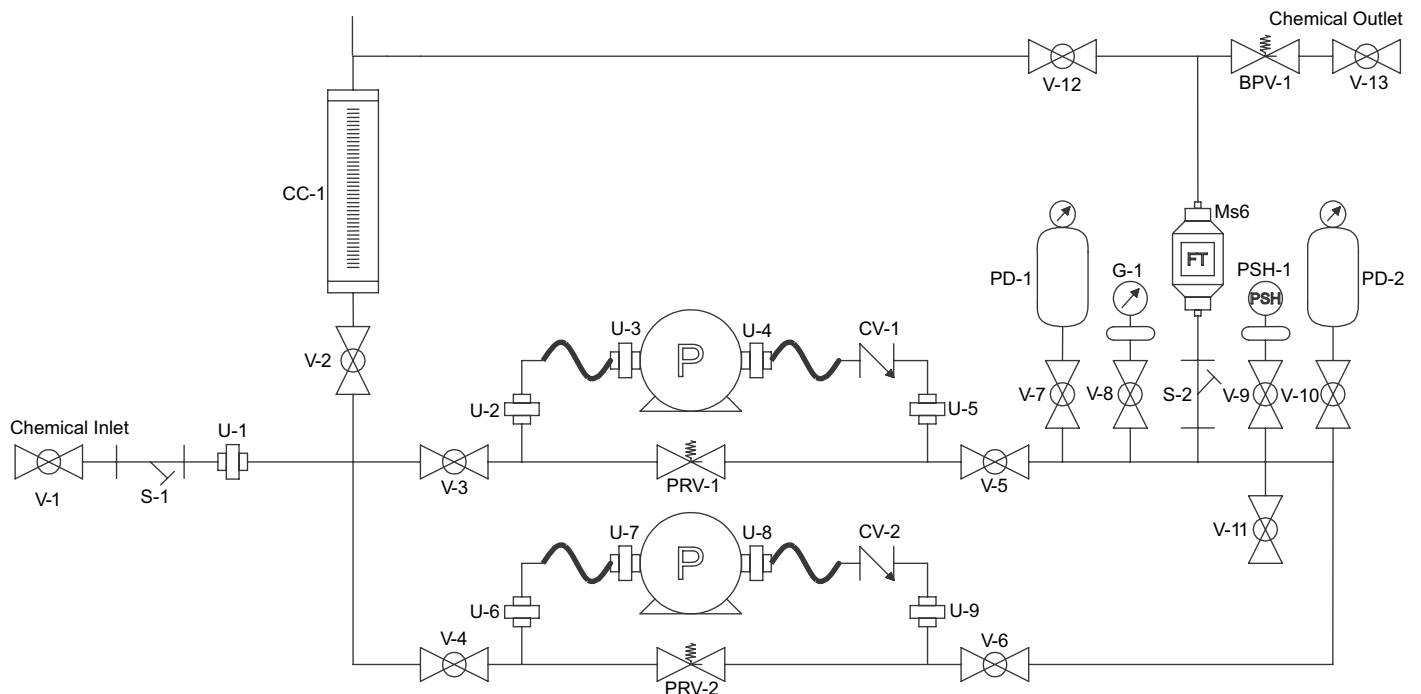

9.0 Chem-Feed® Skid System Matrix

Model Number Matrix

C

CHEM-FEED® Simplex Wall Skid System Matrix - Municipal

CFWS-1 Single pump system - single chemical / single outlet, PE structure

Inlet/Outlet

A	Single Inlet / Single Outlet
X	None, Skid Panel Only

Piping/Unions

A	PVC	C	PVDF
B	CPVC	D	CHEM PROLINE®

Seals

V	FKM	E	EPDM
----------	-----	----------	------

Tubing Connections (Verify tubing connection matches pump outlet when ordering)

A	1/2" ID PVC Braided	C	1/4" ID PE
B	1/2" ID PTFE	D	1/4" ID PTFE

Calibration Column

A	128 GPH (4000 mL) PVC	F	3 GPH (100 mL) PVC
B	64 GPH (2000 mL) PVC	P	32 GPH (1000 mL) Glass
C	32 GPH (1000 mL) PVC	Q	16 GPH (500 mL) Glass
D	16 GPH (500 mL) PVC	R	6 GPH (200 mL) Glass
E	8 GPH (250 mL) PVC	S	3 GPH (100 mL) Glass

Pulsation Dampener

P	10 cubic in	X	Not Included
----------	-------------	----------	--------------

Back Pressure Valve

B	Included	X	Not Included
----------	----------	----------	--------------

Pressure Gauge w/Guard

A	200 PSI	B	100 PSI	C	30 PSI
----------	---------	----------	---------	----------	--------

Pressure Switch w/Guard

S	Included	X	Not Included
----------	----------	----------	--------------

Flow Meter w/Strainer

A	10-5000 mL/min
B	100-10000 mL/min
X	Not Included

*reference Adapter Kits Sheet 85000-198 when ordering with pumps utilizing "M = 1/2" MNPT " or "F = 1/2" FNPT" connections.

CFWS-1 M A A V A A P B A S A X X Sample Model Number

NOTES: When ordering pumps for skids, pump head orientation is standard LEFT facing only. Terminal Boxes quoted and mounted separately. All skids are pressure tested prior to shipment. Pumps are purchased and shipped separately. Contact factory for quote/pricing on 5-point performance testing. Customer is responsible for ensuring skid components are compatible with any chemicals being used.

Model Number Matrix

CHEM-FEED® Duplex Wall Skid System Matrix - Municipal

CFWS-2 Duplex pump system - single chemical / single outlet, PE structure

Inlet/Outlet

A	Single Inlet / Single Outlet
X	None, Skid Panel Only

Piping/Unions

A	PVC	C	PVDF
B	CPVC	D	CHEM PROLINE®

Seals

V	FKM	E	EPDM
----------	-----	----------	------

Tubing Connections (Verify tubing connection matches pump outlet when ordering)

A	1/2" ID PVC Braided	C	1/4" ID PE
B	1/2" ID PTFE	D	1/4" ID PTFE

Calibration Column

A	128 GPH (4000 mL) PVC	F	3 GPH (100 mL) PVC
B	64 GPH (2000 mL) PVC	P	32 GPH (1000 mL) Glass
C	32 GPH (1000 mL) PVC	Q	16 GPH (500 mL) Glass
D	16 GPH (500 mL) PVC	R	6 GPH (200 mL) Glass
E	8 GPH (250 mL) PVC	S	3 GPH (100 mL) Glass

Pulsation Dampener (10 cubic in.)

P	Two Dampeners	D	One Dampener	X	Not Included
----------	---------------	----------	--------------	----------	--------------

Back Pressure Valve

B	Included	X	Not Included
----------	----------	----------	--------------

Pressure Gauge w/Guard

A	200 PSI	B	100 PSI	C	30 PSI
----------	---------	----------	---------	----------	--------

Pressure Switch w/Guard

S	Included	X	Not Included
----------	----------	----------	--------------

Flow Meter w/Strainer

A	10-5000 mL/min
B	100-10000 mL/min
X	Not Included

*reference Adapter Kits Sheet 85000-198 when ordering with pumps utilizing "M = 1/2"MNPT" or "F = 1/2"FNPT" connections.

CFWS-2	M	A	A	V	A	A	P	B	A	S	A	X	X	Sample Model Number
---------------	----------	----------	----------	----------	----------	----------	----------	----------	----------	----------	----------	----------	----------	----------------------------

NOTES: When ordering pumps for skids, pump head orientation is standard LEFT facing only. Terminal Boxes quoted and mounted separately. All skids are pressure tested prior to shipment. Pumps are purchased and shipped separately. Contact factory for quote/pricing on 5-point performance testing. Customer is responsible for ensuring skid components are compatible with any chemicals being used.

10.0 WARRANTY

10.1 Limited Warranty

The skid is a quality product and is warranted for 24 months from date of purchase (proof of purchase is required). The skid will be repaired or replaced at our discretion. The pump(s) have a separate warranty and are not covered under this warranty.

10.2 What is not Covered

- > **The pump(s) included with skid have a separate warranty. Refer to pump warranty page for information.**
- > **Removal, or re-installation, and any related labor charge.**
- > **Freight to the factory.**
- > **Skids that have been tampered with, or in pieces.**
- > **Damage to the skid that results from misuse, carelessness, abuse, lack of maintenance, or alteration that is out of Blue-White's control.**
- > **Skids damaged by or acts of nature.**

Blue-White does not assume responsibility for any loss, damage, or expense directly or indirectly related to or arising out of the use of its products. Failure must have occurred due to defect in material or workmanship and not as a result of operation of the product other than in normal operation as defined in the pump operation manual.

The warranty status is determined by the skid's serial label and the sales invoice or receipt. The serial label must be on the skid and be legible. The warranty status of the skid will be verified by Blue-White or a factory authorized service center.

10.3 Obtaining In-Warranty Repair

Contact the factory to obtain a RMA (Return Material Authorization) number. Carefully pack the system as instructed. Please enclose a brief description of the problem as well as the original invoice or sales receipt, or copy showing the date of purchase. Prepay all shipping costs. COD shipments will not be accepted. Warranty service must be performed by the factory or an authorized service center. Damage caused by improper packaging is the responsibility of the sender. When In-Warranty repair or replacement is completed, the factory pays for return shipping to the dealer or customer.

10.4 Product Use Warning

Blue-White products are manufactured to meet the highest quality standards in the industry. Each product instruction manual includes a description of the associated product warranty and provides the user with important safety information. Purchasers, installers, and operators of Blue-White products should take the time to inform themselves about the safe operation of these products. In addition, Customers are expected to do their own due diligence regarding which products and materials are best suited for their intended applications. Blue-White is pleased to assist in this effort but does not guarantee the suitability of any particular product for any specific application as Blue-White does not have the same degree of familiarity with the application that the customer/end user has. While Blue-White will honor all of its product warranties according to their terms and conditions, Blue-White shall only be obligated to repair or replace its defective parts or products in accordance with the associated product warranties. **BLUE-WHITE SHALL NOT BE LIABLE EITHER IN TORT OR IN CONTRACT FOR ANY LOSS OR DAMAGE WHETHER DIRECT, INDIRECT, INCIDENTAL, OR CONSEQUENTIAL, ARISING OUT OF OR RELATED TO THE FAILURE OF ANY OF ITS PARTS OR PRODUCTS OR OF THEIR UNSUITABILITY FOR A GIVEN PURPOSE OR APPLICATION.**

10.5 Chemical Resistance Warning

Blue-White offers a wide variety of wetted parts. Purchasers, installers, and operators of Blue-White products must be well informed and aware of the precautions to be taken when injecting or measuring various chemicals, especially those considered to be irritants, contaminants or hazardous. Customers are expected to do their own due diligence regarding which products and materials are best suited for their applications, particularly as it may relate to the potential effects of certain chemicals on Blue-White products and the potential for adverse chemical interactions.

Blue-White tests its products with water only. The chemical resistance information included in this instruction manual was supplied to Blue-White by reputable sources, but Blue-White is not able to vouch for the accuracy or completeness thereof. While Blue-White will honor all of its product warranties according to their terms and conditions, Blue-White shall only be obligated to repair or replace its defective parts or products in accordance with the associated product warranties.

BLUE-WHITE SHALL NOT BE LIABLE EITHER IN TORT OR IN CONTRACT FOR ANY LOSS OR DAMAGE, WHETHER DIRECT, INDIRECT, INCIDENTAL, OR CONSEQUENTIAL, ARISING OUT OF OR RELATED TO THE USE OF CHEMICALS IN CONNECTION WITH ANY BLUE-WHITE PRODUCTS.

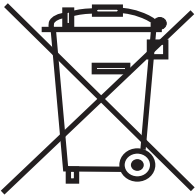

Users of electrical and electronic equipment (EEE) with the WEEE marking per Annex IV of the WEEE Directive must not dispose of end of life EEE as unsorted municipal waste, but use the collection framework available to them for the return, recycle, recovery of WEEE and minimize any potential effects of EEE on the environment and human health due to the presence of hazardous substances. The WEEE marking applies only to countries within the European Union (EU) and Norway. Appliances are labeled in accordance with European Directive 2002/96/EC.

Contact your local waste recovery agency for a *Designated Collection Facility* in your area.

Blue-White[®]

5300 Business Drive
Huntington Beach, CA 92649
USA

TEL: 714-893-8529
FAX: 714-894-9492

www.blue-white.com
sales@blue-white.com
customerservice@blue-white.com