

# **FLEXFLO**<sup>®</sup>

Peristaltic Metering Pump

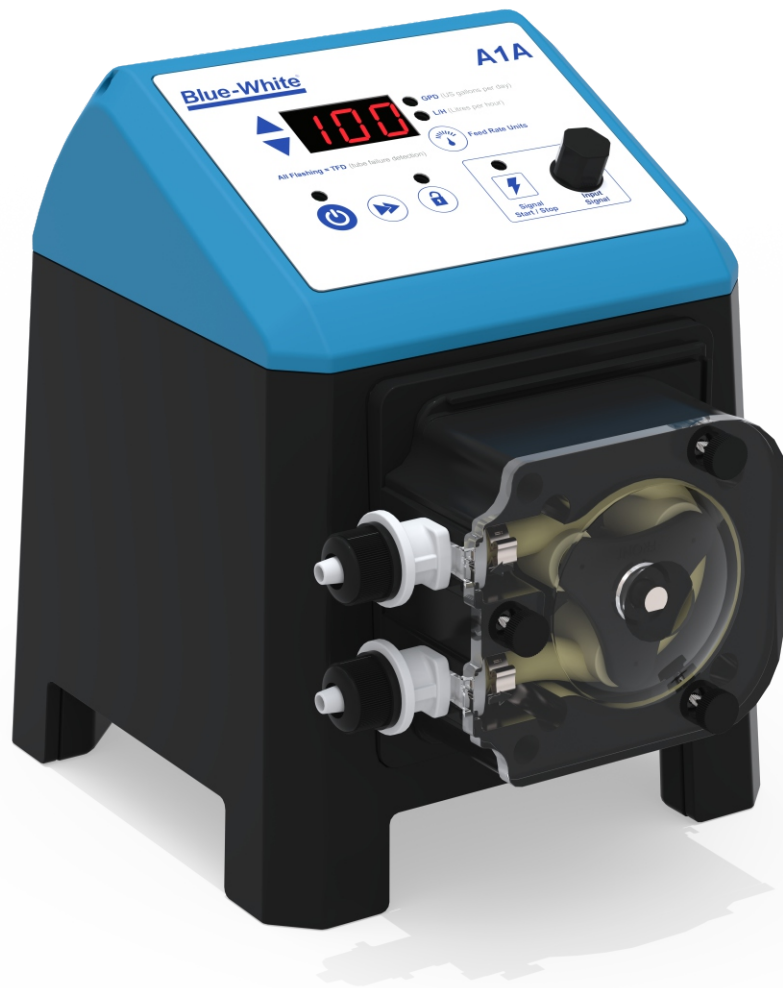

## **Series A1A**

<b>1.0</b>	<b>INTRODUCTION</b>	<b>4</b>
	1.1 Available Models	4
<b>2.0</b>	<b>ENGINEERING SPECIFICATIONS</b>	<b>5</b>
<b>3.0</b>	<b>CONSTRUCTION MATERIALS</b>	<b>6</b>
	3.1 Wetted Components	6
	3.2 Non-Wetted Components	6
<b>4.0</b>	<b>FEATURES</b>	<b>7</b>
	4.1 Agency Listings	7
<b>5.0</b>	<b>INSTALLATION</b>	<b>8</b>
	5.1 Mounting Location	8
	5.2 Wall Mounting	9
	5.3 Installing Injection Fitting and Strainer	10
<b>6.0</b>	<b>POWER CONNECTIONS</b>	<b>11</b>
<b>7.0</b>	<b>TOUCHPAD LAYOUT</b>	<b>12</b>
	7.1 IO Connection	13
	7.2 Operation Mode	14
<b>8.0</b>	<b>OUTPUT ADJUSTMENT</b>	<b>15</b>
<b>9.0</b>	<b>TUBE FAILURE DETECTION (TFD)</b>	<b>16</b>
	9.1 Confirming Chemical Detection	16
<b>10.0</b>	<b>PUMP MAINTENANCE</b>	<b>17</b>
	10.1 Routine Inspection and Maintenance	17
	10.2 Cleaning and Lubricating the Pump	17
<b>11.0</b>	<b>TUBE REPLACEMENT</b>	<b>18</b>
	11.1 Tube Removal	18
	11.2 Tube Installation	20
<b>12.0</b>	<b>ACCESSORIES</b>	<b>22</b>
<b>13.0</b>	<b>PUMP HEAD REPLACEMENT PARTS LIST</b>	<b>23</b>
<b>14.0</b>	<b>TROUBLESHOOTING</b>	<b>24</b>
<b>15.0</b>	<b>WARRANTY</b>	<b>25</b>
<b>APPENDIX A:</b>	<b>Accronyms</b>	<b>26</b>
<b>APPENDIX B:</b>	<b>Warranty</b>	<b>27</b>

# READ THE ENTIRE OPERATING MANUAL PRIOR TO INSTALLATION AND USE.



+1 (714) 893 - 8529



[sales@blue-white.com](mailto:sales@blue-white.com)



[customerservice@blue-white.com](mailto:customerservice@blue-white.com)



5300 Business Drive  
Huntington Beach, CA 92649

## 1.0 INTRODUCTION

Congratulations on purchasing Blue-White's FlexFlo® Series A1A variable speed, peristaltic metering pump (a peristaltic metering pump is a type of positive displacement pump used for pumping a variety of fluids).

The FlexFlo® Series A1A variable speed, peristaltic metering pump is pre-configured for the tubing that is shipped with it.

**NOTE:** It is recommended that the pump have a one-hour break-in period before calibrating the new tube.

**NOTE:** The tubing has an identification number printed on the tube for easy re-ordering.

**NOTE:** The pump was pressure-tested at the factory with clean water before it was shipped, so there may be trace amounts of clean water in the pre-installed tube assembly.

## 1.1 Available Models

### A1A Pumps with Flex-A-Prene® Tube

Feed Rate		Maximum Pressure PSI (bar)	Maximum Temperature °F (°C)	A1A Model Numbers	
GPD	LPH			115V AC	220V AC
0.01-100	0.01-15.8	40 (2.76)	185 (85)	A1A4-7T	A1A6-7T

## 1.2 What's in the Box

- Blue-White FLEXFLO® Series A1A peristaltic metering pump
- Power Cord (if ordered)
- One installed tube.
- Injection Valve and Foot Strainer.
- Suction Tubing and Discharge Tubing (10 feet)
- Mounting Hardware Kit / Rear Bracket
- Display Shield
- Instruction Manual

See Accessory page for additional options (Tanks, M8 Cable, Power Cords, Pump Shelf)

## 2.0 ENGINEERING SPECIFICATIONS

<b>Maximum Working Pressure</b>	40 PSI (2.76 bar)
<b>Maximum Suction Lift</b>	30 ft. of water at sea level (14.7 atm psi)
<b>Ambient Operating Temperature</b>	14°F to 125°F (-10°C to 52°C)
<b>Ambient Storage Temperature</b>	-40°F to 158°F (-40°C to 70°C)
<b>Operating Voltage</b>	115V60Hz 1 PH (0.6A max.) 220V50Hz 1 PH (0.3A max.) 230V60Hz 1 PH (0.3A max.) 230V50Hz 1 PH (0.3A max.) 240V50Hz 1 PH (0.3A max.)
<b>Power Cord Options</b>	115V50/60Hz = NEMA 5/15 (USA) 230V50/60Hz = NEMA 6/15 (USA) 220V50/60Hz = CEE 7/VII (EU) 240V50/60Hz = AS 3112 (Australia/New Zealand)
<b>Motor</b>	Brushless DC, 50W.
<b>Duty Cycle</b>	Continuous
<b>Flow Range Adjustment</b>	0.01 - 100 GPD (0.01 - 15.8 LPH)
<b>Enclosure</b>	NEMA 4X (IP66), Valox® (PBT) & PA12
<b>Maximum Overall Dimensions</b>	7.25" W x 9" H x 10" D (18.5 W x 22.9 H x 25.2 D cm)
<b>Product Weight</b>	6 lb. (2.7 Kg)
<b>Approximate Shipping Weight</b>	13 lb. (5.9 Kg)
<b>Approximate Shipping Dimensions</b>	10.5" W x 13.75" H x 11" D (26.7 W x 35 H x 28 D cm)

### 3.0 CONSTRUCTION MATERIALS

#### 3.1 Wetted Components

##### Pump Tube Assembly

Tubing	Flex-A-Prene®
Adapter Fittings	PVDF

##### Injection / Back-Flow Check Valve

Body & Insert	Polypropylene
Check Ball	Ceramic
Spring	Hastelloy C-276
Ball Seat O-Ring	TFE/P
Static Seal O-Ring	FKM

##### Ancillary Items Provided

Suction Tubing	3/8" OD x 1/4" ID x 10' Clear PVC
Discharge Tubing	3/8" OD x 1/4" ID x 10' Polyethylene (LLDPE)
Suction Strainer	Polypropylene

#### 3.2 Non-Wetted Components

Enclosure	Valox® (PBT)
Pump Head	Valox® (PBT) thermoplastic
Pump Head Cover	Polycarbonate for added strength and chemical resistance. Permanently lubricated sealed motor shaft support ball bearing.
Cover Screws	Stainless steel, polypropylene cap
Roller Assembly	
Rotor	Valox® (PBT)
Rollers	Nylon
Roller Bearings	Bronze
TFD System Sensor Pins	Hastelloy C-276
Power Cord	3 conductor, SJTW-A water-resistant
Mounting Brackets and Hardware	316 stainless steel screws GF nylon bracket

### 4.0 Features

- ▶ Self-priming (even against maximum line pressure), which means no required bypass valves, and it cannot vapor lock or lose prime.
- ▶ Output rates from .01 to 100 GPD (.01 to 15.8 LPH).
- ▶ Pressure up to 40 PSI (2.76 bar).
- ▶ Variable speed brushless DC motor.
- ▶ Exclusive Tube Failure Detection (TFD) system, which senses tube failure by detecting chemical in the pump head, shuts off the pump, and activates a 48 VDC @ 80 mA relay. No false triggering.
- ▶ Remote Start/Stop, which is non-powered dry contact closure.
- ▶ Three-nylon, molded squeeze rollers for optimum squeeze, high accuracy, and long tube life.
- ▶ Heavy duty rotor that has a single piece, plastic rotor for no flexing, and high accuracy with no corroding metal springs or hinges.
- ▶ Chemical-resistant tubing capable of pumping bleach (sodium hypochlorite), calcium hypochlorite 20%, and muriatic acid (hydrochloric acid).
- ▶ Rated for continuous duty.

### 4.1 Agency Listings



This pump is ETL listed to conform to the following: UL Standard 1081 as a motor operated water pump. CSA Standard C22.2 as process control equipment



This pump complies to the Machinery Directive 2006/42/EC, BS, EN 60204-1, Low Voltage Directive 2014/35/EU BS EN 61010-1, EMC Directive 2014/30/EU, BS EN 50081-1/BS EN 50082-1.



This pump is certified to NSF/ANSI Standard 50 - Equipment for Swimming Pools, Spas, Hot Tubs, and Other Recreational Water Facilities

Symbol	Description
	Warning (Risk of electric shock)
	Caution (Refer to the user's guide)
	Ground, Protective Conductor Terminal

## ENCLOSURE RATING

- NEMA 4X** Constructed for either indoor or outdoor use to provide a degree of protection to personnel against incidental contact with enclosed equipment; to provide a degree of protection against falling dirt, rain, sleet, snow, windblown dust, splashing water, and hose-directed water; and that will be undamaged by external formation of ice on enclosure.
- IP66** No ingress of dust; complete protection against contact. Water projected in powerful jets against enclosure from any direction shall have no harmful effects.

## 5.0 INSTALLATION

### CAUTION



The pump should be serviced by qualified persons only. If equipment is used in a manner not specified in this manual, the protection provided by the equipment may be impaired.

### CAUTION



Risk of chemical overdose. Be certain pump does not overdose chemical during backwash and periods of no flow in circulation system.

### CAUTION



Always wear protective clothing, face shield, safety glasses and gloves when working on or near your metering pump. Additional precautions should be taken depending on solution being pumped. Refer to MSDS precautions from your solution supplier.

### CAUTION



All diagrams are strictly for guideline purposes only. Always consult an expert before installing metering pump on specialized systems. Metering pump should be serviced by qualified persons only.

### CAUTION



Be sure that installation does not constitute a cross connection with drinking water supply. Check your local plumbing codes.

### CAUTION



The pump should be supplied by an isolating transformer or RCD (operating current less or equal 30 mA).

## 5.1 Mounting Location

1. Choose an area located near the chemical supply tank, chemical injection point, and electrical supply. Also, choose an area where the pump can be easily serviced. The pump must be sheltered from environment (rain, snow, direct sunlight, etc.) Do not place pump on the floor or in location with excessive chemical spills or vapors.
2. Finding a secure surface and using the provided mounting hardware, mount the pump close to the injection point. Keep the inlet (suction) and outlet (discharge) tubing as short as possible. Longer discharge tubing increases back pressure at pump head.

**NOTE:** Mounting the pump lower than the chemical container will gravity-feed chemical into it. This “flooded suction” installation may minimize output variation by eliminating suction lift, and minimizing air and gasses entering the pump due to off-gassing and suction line leaks. A shut-off valve, pinch-clamp, or other means to halt gravity-feed to the pump must be installed during servicing.

**NOTE:** Install a back flow prevention check valve at the discharge side of the pump to prevent the system fluid from flowing back through pump during tube replacement or during tube leak.

**NOTE:** It is recommended to have a pressure relief valve at the discharge side of the of pump to prevent premature wear and damage to the pump tube, in the event that the discharge line becomes blocked.

**NOTE:** The pump does not require back pressure. Keep the discharge pressure as low as possible to maximize the tube life.



## 5.2 Wall Mounting

- Using #10 self-tapping screws, mount the bracket to a secure wall that is located where it can be easily serviced.

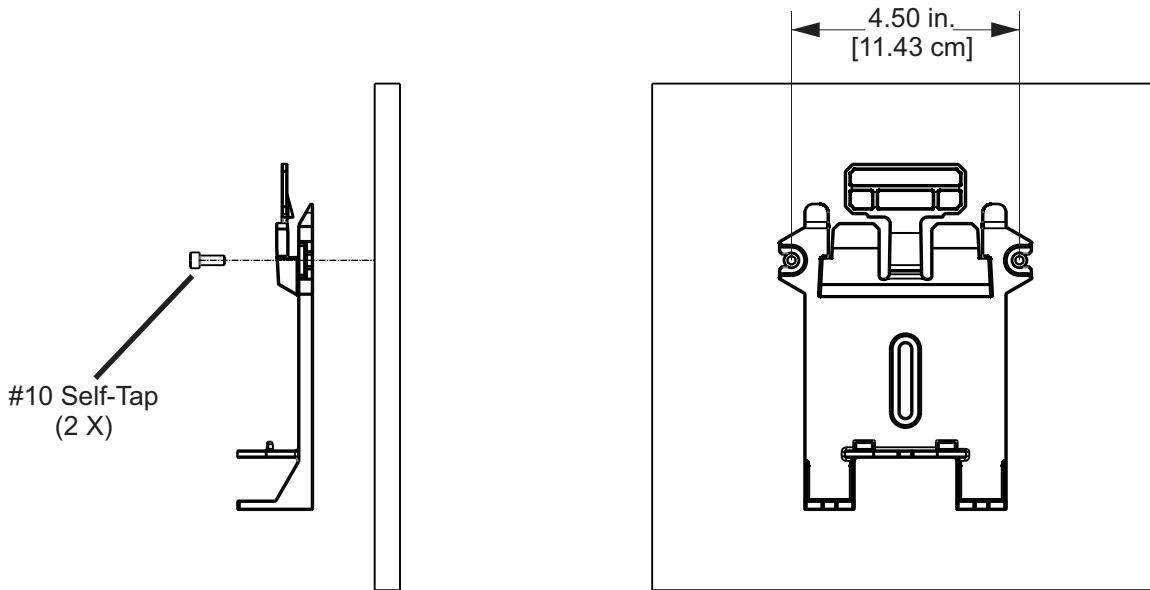

**Wall Mount Bracket (Side View)**

**Mounted Pump (Front View)**

Note: If mounting bracket to shelf, table, or floor, we recommend using mounting holes on bracket feet and using hardware appropriate for base surface. See Accessories for Wall Shelf options.

- Lower the pump so that the tab on the wall mount is inserted into the slot located on the back of the pump. The pump will now be secured to the wall mount bracket. To remove, pull tab forward and lift pump.

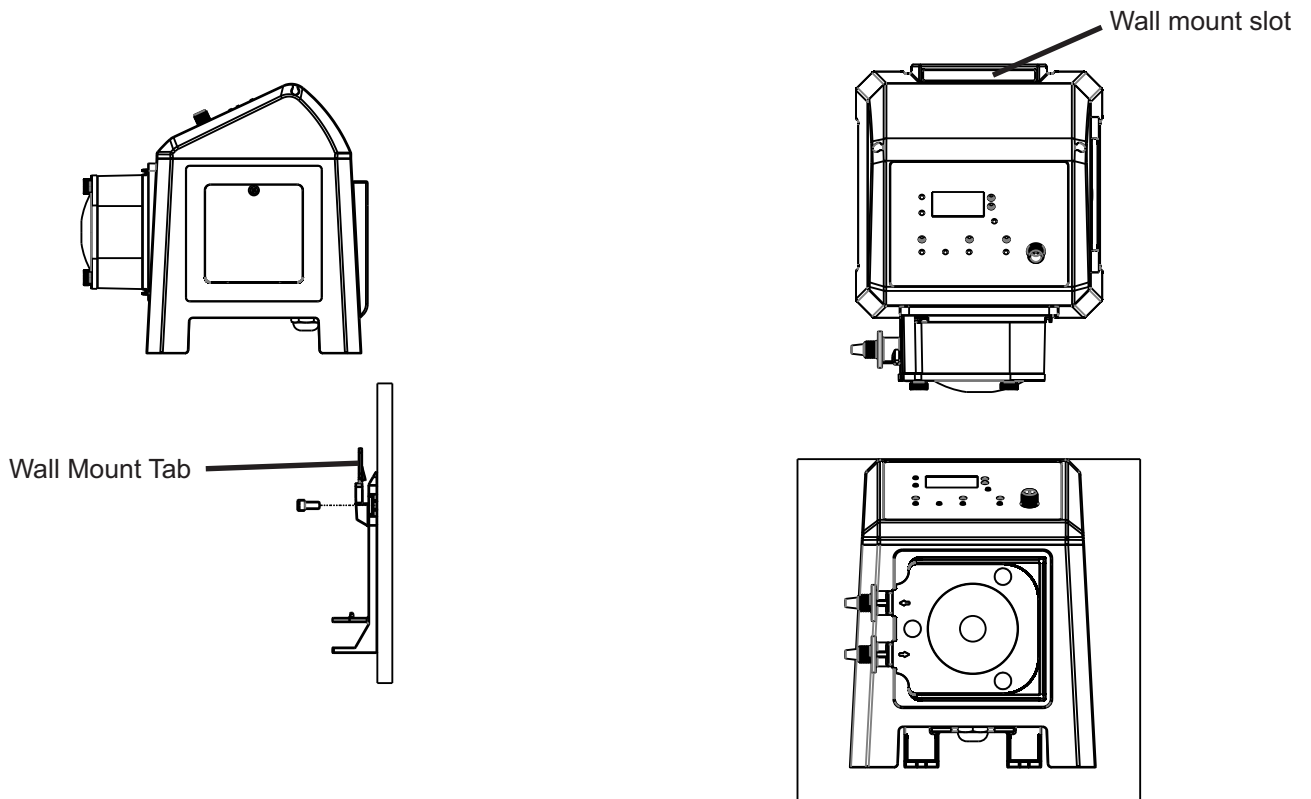

**Wall Mount (Side View)**

**Mounted Pump**

### 5.3 Installing Injection Fitting and Strainer



Proper eye and skin protection must be worn when installing and servicing pump.

Assemble the injection fitting and strainer per the figures below.

**NOTE:** Install upward for best results.

**NOTE:** The injection nose may be trimmed (removed) when injecting into a small pipe.

**INJECTION FITTING AND STRAINER FOR 1/4" (0.64 CM) I.D. CONNECTION END MODELS**

<b>Discharge Injection Fitting / Check Valve</b>	<b>Suction Tubing and Strainer</b>
--	------------------------------------

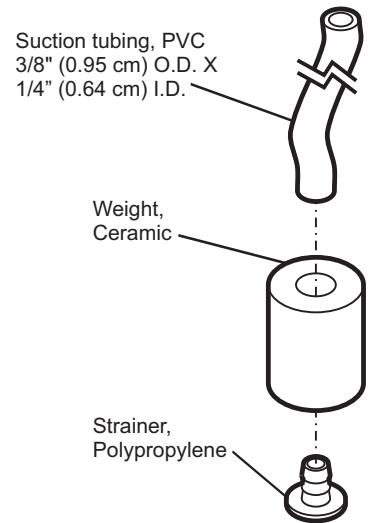
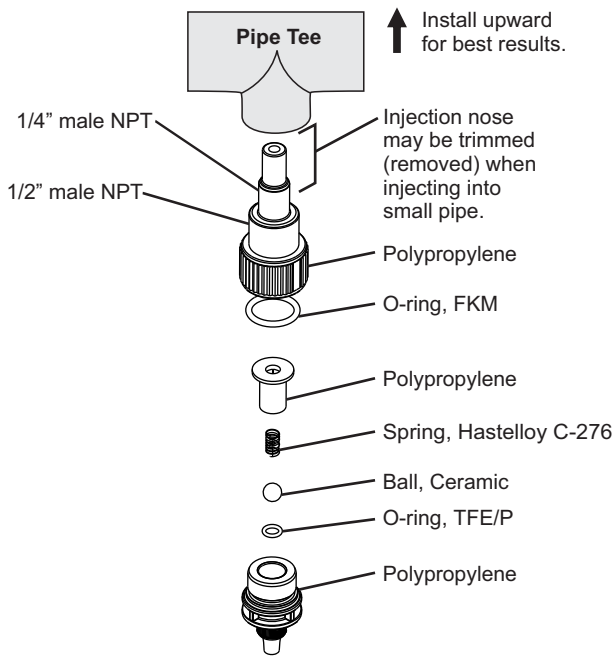

## 6.0 POWER CONNECTIONS

**WARNING**

Risk of electric shock – cord connected models are supplied with a grounding conductor and grounding-type attachment plug. To reduce risk of electric shock, be certain that it is connected only to a properly grounded, grounding-type receptacle.

**WARNING**

Electrical connections and grounding (earthing) must conform to local wiring codes. Be certain that a grounding conductor is connected to terminal T11-1 located in wiring compartment.

**WARNING**

Risk of electric shock - Disconnect electricity before removing wiring compartment cover.

**WARNING**

Ensure to connect the pump to the proper supply voltage. Using the incorrect voltage will damage the pump and may result in injury. The voltage requirements is printed on the pump serial label.

- ▶ Use the voltage for which the power cord is rated.
- ▶ To prevent electronic noise interference, electronic signal wires and AC power wires must be kept separate. Do not bundle these cables together or run within the same conduit.
- ▶ When there is a power interruption, the pump, which has an auto-restart feature, will restore the pump to the operating state it was in when the power was lost.
- ▶ POWER: 115V60Hz (0.6A max.), 220V50Hz (0.3A max.), 230V60Hz (0.3A max.), 230V50Hz (0.3A max.), 240V50Hz (0.3A max.)

**NOTE:** When in doubt regarding your electrical installation, contact a licensed electrician.

7.0 TOUCHPAD LAYOUT

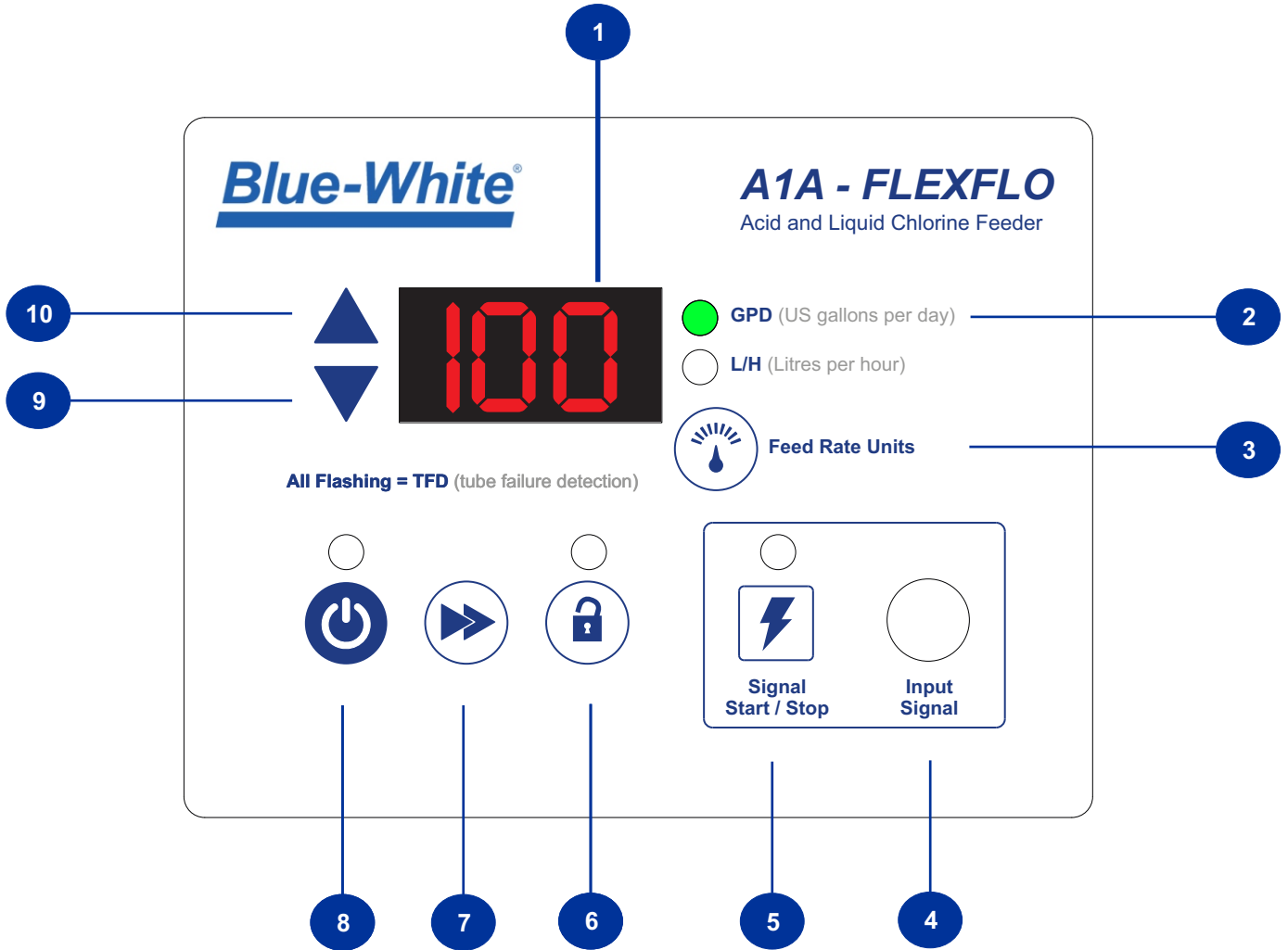

Item Number	Item
1	LED/LCD Readout
2	Unit of Measurement
3	Rate Display Key
4	M8 Input Key
5	Remote Start/Stop Key
6	Lock-Out Key
7	Prime Key
8	Start & Stop Key
9	Down Key
10	Up Key

## 7.1 IO Connection



Risk of electric shock - All wiring must be insulated and rated 300V minimum.

### 4-Pin M8 Connector (on pump)

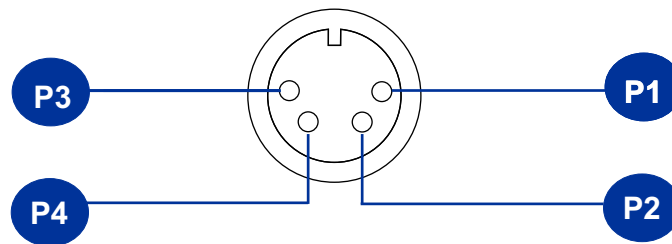

PIN	Function	Specifications
P3	Relay (TFD)	48 VDC @ 80 mA MAX.
P4	Relay (TFD)	48 VDC @ 80 mA MAX.
P1	Remote Start/Stop	N.O. dry contact closure
P2	Ground	DC ground

TFD = Tube Failure Detection. P3/P4 will close if leak is detected.

#### Blue-White M8 Cable Pin wire color:

**P1 = Brown**

**P2 = White**

**P3 = Blue**

**P4 = Black**

## 7.2 Operation Mode

Start & Stop Key LED	Signal Key LED	P1-P2 Pins	Status
Red	X	X	Stop
Green	Off	X	Run
Green	Green (N.O.)	Close	Run
Green	Green (N.O.)	Open	Stop
Green	Red (N.C.)	Close	Stop
Green	Red (N.C.)	Open	Run

### How to Change the Signal Key LED Color

To change the Signal Key LED color, press and hold the Signal Key button for 5-7 seconds.

Green = Normally Open

Red = Normally Closed

## 8.0 OUTPUT ADJUSTMENT

Speed of pumping mechanism is adjustable from 0.01 GPD to 100 GPD (0.01 LPH to 15.8 LPH).

Use Up Arrow and Down Arrow to adjust pump speed. Hold buttons down for faster adjustment.

Prime button will run pump at 100% speed for 60 seconds. Press start/stop button at any time to stop.

Lock button (press/hold for 5 seconds to activate = green) will prevent pump speed adjustment and priming.

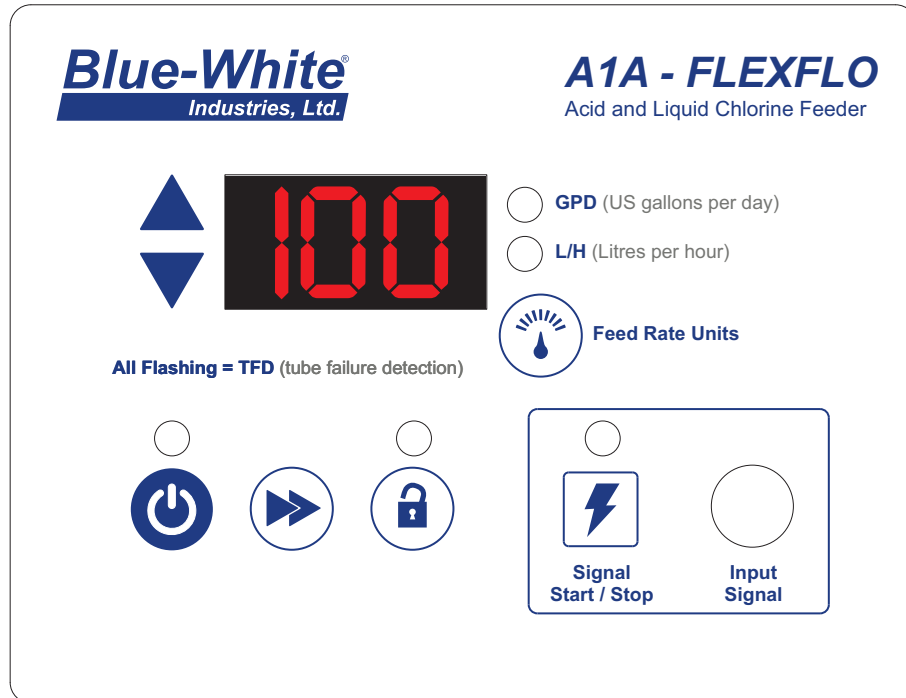

## 9.0 TUBE FAILURE DETECTION (TFD)

The pump is equipped with a Tube Failure Detection (TFD) system, which is designed to stop the pump and provide an output alarm in the event the pump tube should rupture, and a chemical enters the pump head. The pump will detect a chemical with a conductivity reading greater than 500 microsiemens. Chemicals with a conductivity of less than 500 microsiemens will not be detected.

This patented system can detect the presence of many chemicals, including sodium hypochlorite (chlorine), hydrochloric (muriatic) acid, sodium hydroxide, and many others. The system will not be triggered by water (rain, condensation, etc.) or silicone oil (roller lubricant).

**NOTE:** If the system has detected a chemical, the pump tube must be replaced, and the pump head and roller assembly must be thoroughly cleaned. Failure to clean the roller assembly will void the warranty.

**NOTE:** If the TFD alarm is triggered, the pump will stop, and close an alarm output. (Pin 3 and Pin 4 on pump M8 Connector)

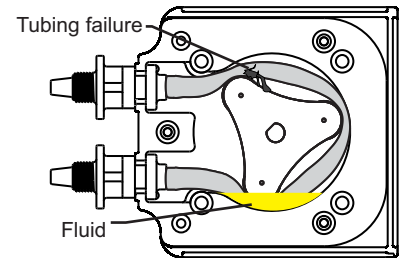

## 9.1 Confirming Chemical Detection

To determine if a chemical will be detected by the system:

1. Remove the pump head cover, and the pump tube and roller assembly.
2. Place a small amount of chemical in the bottom of the pump head that is enough to cover the sensors.
3. Replace **only** the pump head cover.
4. Turn on the pump by pressing the Start & Stop key.

**NOTE:** If the TFD system **detects** a chemical, the pump will stop after a two-second confirmation period.

**NOTE:** If the TFD system **does not detect** a chemical, the pump will continue to operate after the confirmation period.

5. Carefully clean the chemical out of the pump head. Ensure to remove all the chemical traces from the sensor probes.
6. Replace the roller assembly and tubing.
7. Replace the pump head cover.
8. Press the Start & Stop key to clear the alarm condition.
9. Restart the pump.



## 10.0 PUMP MAINTENANCE



Always wear protective clothing, face shield, safety glasses and gloves when working on or near your metering pump. Additional precautions should be taken depending on solution being pumped. Refer to MSDS precautions from your solution supplier.

### 10.1 Routine Inspection and Maintenance

The pump requires minimal maintenance. However, the pump and all the accessories should be checked weekly, especially when pumping chemicals. Inspect all the components for signs of leaking, swelling, cracking, discoloration, or corrosion. Immediately replace worn out or damaged components.

Cracking, crazing, or discoloration during the first week of operation are signs of a severe chemical attack. If this occurs, perform the following steps:

1. Immediately remove the chemical from the pump.
2. Determine which parts are being attacked.
3. Replace the damaged parts with parts that have been manufactured using more suitable materials.
4. After servicing, operate the pump to verify normal operation.

**NOTE:** The manufacturer does not assume responsibility for damage to a pump that has been caused by a chemical attack.

### 10.2 Cleaning and Lubricating the Pump

- ▶ The pump will require occasional cleaning, and it will depend on the severity of service.
- ▶ When changing the pump tube assembly, the pump head chamber, the roller assembly, and the pump head cover should be wiped of any dirt and debris.
- ▶ Clean the motor shaft with a clean towel, and then apply a small amount of grease to the shaft. This will help prevent the rotor from sticking to the motor shaft.
- ▶ Periodically, or when necessary, grease the pump head cover bearing. Apply a small amount of grease (Aeroshell aviation grease #5 or equivalent).
- ▶ 100% silicone lubrication may be used on the roller assembly.
- ▶ Periodically clean the injection fitting /check valve assembly, especially since injecting fluids, like sodium hypochlorite, can calcify. These lime deposits and other buildups can clog the fitting, increase back pressure, and interfere with the check valve operation.
- ▶ Periodically clean the suction strainer.

## 11.0 TUBE REPLACEMENT

### CAUTION



Prior to service, pump clean water through the pump and suction / discharge line to remove any chemical.

### CAUTION



Always wear protective clothing, face shield, safety glasses and gloves when working on or near your metering pump. Additional precautions should be taken depending on solution being pumped. Refer to MSDS precautions from your solution supplier.

### CAUTION



Use the provided Tube Installation Tool to leverage tubing into the pump head. **Do not use your fingers.**

### CAUTION



Use extreme caution when replacing the pump tube. **Do not place your fingers near the rollers.**

The pump tube assembly will eventually become non-operational if it is not regularly inspected and replaced. The tube life is affected by many factors, such as the type of chemical being pumped, the amount of back pressure, the motor revolutions per minute (RPM), and temperature.

## 11.1 Tube Removal

### CAUTION



**Safety first. Remove the pressure.** Relieve (remove) the system pressure on the discharge and suction side of the pump. Failure to do so will cause the solution to squirt when disconnecting the tube connections.

Tube replacement and pump maintenance video can be found by visiting How To section of videos at The Blue-White Academy.  
[1 Series Tube Replacement and Maintenance.](#)

Or scan the QR Code



1. Disconnect the system plumbing from the pump tube adapters.
2. Press the Start & Stop key to stop the pump.
3. Remove the three black thumb screws from the front of the pump head cover by unscrewing counterclockwise. Remove the pump head cover by pulling straight out.



4. Press the Start & Stop key to start the pump and set the pump to 6 GPD (1 LPH).
5. With the pump running, pull the inlet (suction) fitting out of the pump head. Guide the tube counterclockwise away from the rollers.



6. Pull the outlet (discharge) fitting out of the pump head.



7. Press the Start & Stop key to stop the pump.

## 11.2 Tube Installation

**NOTE:** Thoroughly clean the pump head and rotor. The rotor can be removed by pulling it straight out. After cleaning, push the rotor back on the shaft.

1. Press Start & Stop key to start the pump.
2. Insert the inlet (suction) side of the pump tube fitting into the lower retaining slot of the pump head. Carefully guide the pump tube into the pump head.

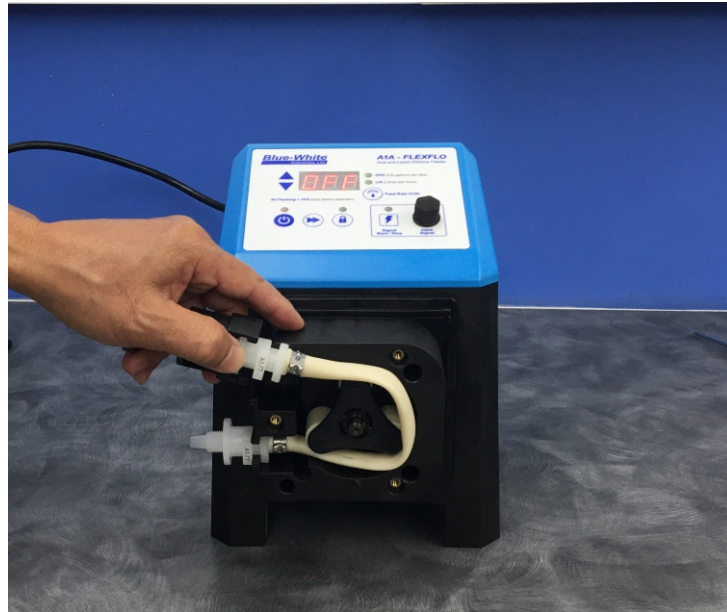

3. Stretch the tube slightly and insert the outlet (discharge) fitting into the upper retaining slot of the pump head.

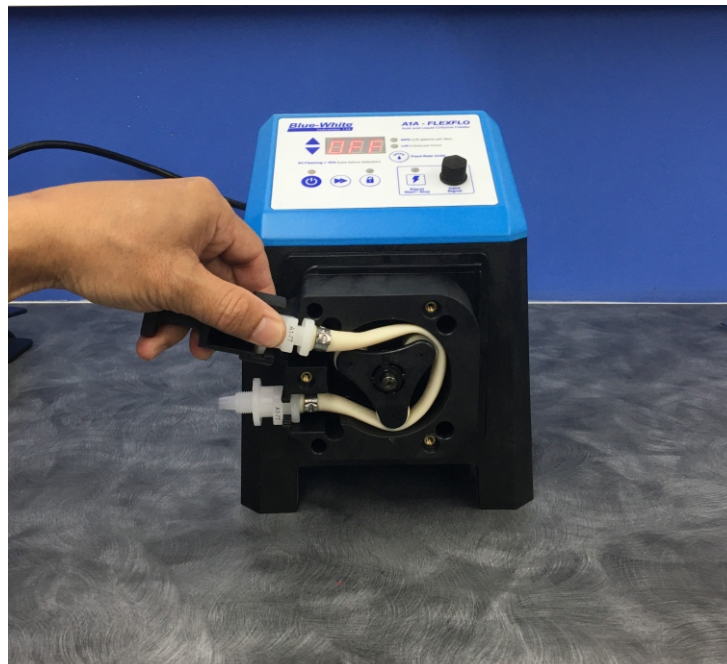

4. Pull the outlet fitting out of the pump head.

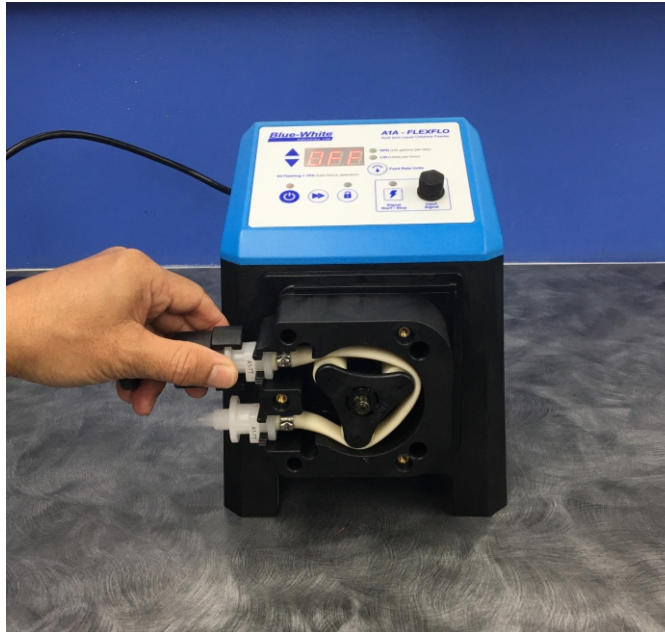

5. Place the clear cover onto the pump head. Secure the cover with the provided three thumb screws. The pump is now ready for operation.



## 12.0 Accessories



### KIT-S07

Kit contains: One 7 gallon tank,, One foot valve and strainer and One mounting bracket with screws



### KIT-S15

Kit contains: One 15 gallon tank, One foot valve and strainer and One mounting bracket with screws



### KIT-S30

Kit contains: One 30 gallon tank, One foot valve and strainer and One mounting bracket with screws



### KIT-PSM

Kit contains: One HDPE Bracket, (4) 3/8" x 2-3/4" long dia anchor bolts.



### CABLE-M8

Contains: One M8 cable.  
5 foot length.

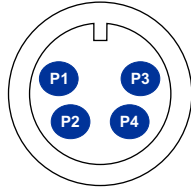
KIT-M8 FEMALE CABLE WIRING		
DIAGRAM	PIN #	WIRE COLOR
	PIN 1	BROWN
	PIN 2	WHITE
	PIN 3	BLUE
	PIN 4	BLACK

**13.0 PUMP HEAD REPLACEMENT PARTS LIST**

Item	Description	Part	Quantity
1	Spacer, back	90011-014	1
2	Roller assembly complete (rotor)	71000-350	1
3	Tube assembly, 3/8" OD tube compression, Flex-A-Prene®	A1-7T	1
4	Pump head cover, polycarbonate	A1-SXX-C	1
5	Thumb screw with 9/64" key drive, maximum torque 6-8 in. lbs. <sup>1</sup>	90011-160	3
6	Tube nut, compression, for 3/8" tubing <sup>2</sup>	C-330-6	2

**NOTES:**

- 1 - Three required per pump. Sold individually.
- 2 - Two required per pump. Sold individually.

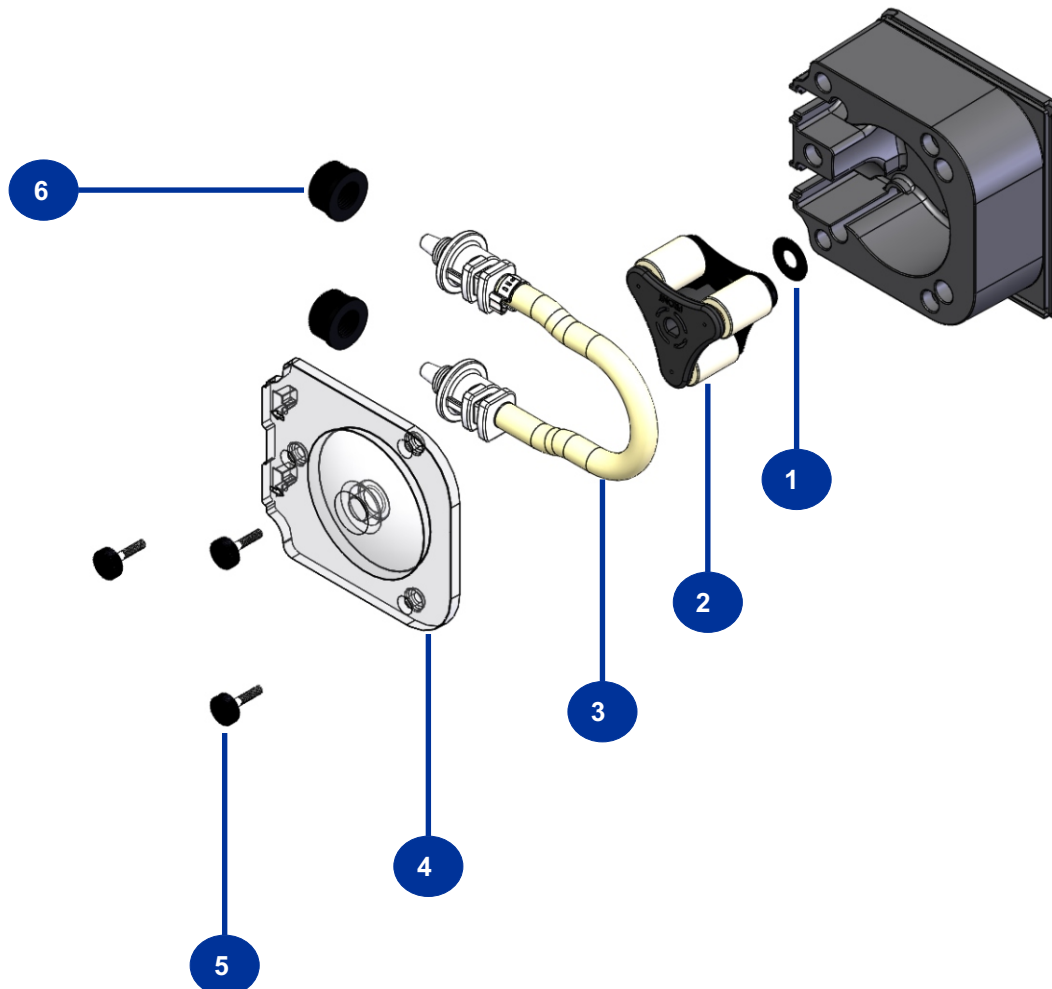

## 14.0 Troubleshooting

Error Code	Explanation	Troubleshooting
<b>E01</b>	Motor Over Current	Check that tube is properly installed
<b>E02</b>	Over Voltage	Check power supply output voltage
<b>E03</b>	Under Voltage	Check power supply output voltage
<b>E04</b>	Temperature exceeds 75°C at control	Check ambient conditions, restart pump once cooled to ambient temperature
<b>E05</b>	Inverter Error	Contact Blue-White Industries (714) 893-8529 customerservice@blue-white.com
<b>E06</b>	No Motor Connection	Contact Blue-White Industries (714) 893-8529 customerservice@blue-white.com
<b>E08</b>	Motor Stall	Check that tube is properly installed
<b>E10</b>	Capacitor bank charging error	Contact Blue-White Industries (714) 893-8529 customerservice@blue-white.com
<b>E17</b>	Communication error at display	Contact Blue-White Industries (714) 893-8529 customerservice@blue-white.com

**For Firmware updates, please contact factory or local service center.**



## 15.0 WARRANTY

### 15.1 LIMITED WARRANTY

Your new FLEXFLO pump is a quality product and is warranted for 24 months from date of purchase (proof of purchase is required). The pump will be repaired or replaced at our discretion. Failure must have occurred due to defect in material or workmanship and not as a result of operation of the product other than in normal operation as defined in the pump manual. Warranty status is determined by the pump's serial label and the sales invoice or receipt. The serial label must be on the pump and legible. The warranty status of the pump will be verified by Blue-White or a factory authorized service center.

Pump Head and roller assembly is warranted against damage from chemical attack when proper TFD (Tube Failure Detection) system instructions and maintenance procedures are followed.

### 15.2 WHAT IS NOT COVERED

- Pump Tube Assemblies and rubber components – They are perishable and require periodic replacement.
- Pump removal, or re-installation, and any related labor charge.
- Freight to the factory, or a certified service center.
- Pumps that have been tampered with, or in pieces.
- Damage to the pump that results from misuse, carelessness such as chemical spills on the enclosure, abuse, lack of maintenance, or alteration which is out of our control.
- Pumps damaged by faulty wiring, power surges or acts of nature.

### 15.3 PROCEDURE FOR IN WARRANTY REPAIR

Contact the factory to obtain a RMA (Return Material Authorization) number. Carefully pack the pump to be repaired. It is recommended to include foot strainer and injection/check valve fitting since these devices may be clogged and part of the problem. Please enclose a brief description of the problem as well as the original invoice or sales receipt, or copy showing the date of purchase. Prepay all shipping costs. COD shipments will not be accepted. Warranty service must be performed by the factory or an authorized service center. Damage caused by improper packaging is the responsibility of the sender. When In-Warranty repair or replacement is completed, the factory pays for return shipping to the dealer or customer.

### 15.4 PRODUCT USE WARNING

Blue-White products are manufactured to meet the highest quality standards in the industry. Each product instruction manual includes a description of the associated product warranty and provides the user with important safety information. Purchasers, installers, and operators of Blue-White products should take the time to inform themselves about the safe operation of these products. In addition, Customers are expected to do their own due diligence regarding which products and materials are best suited for their intended applications. Blue-White is pleased to assist in this effort but does not guarantee the suitability of any particular product for any specific application as Blue-White does not have the same degree of familiarity with the application that the customer/end user has. While Blue-White will honor all of its product warranties according to their terms and conditions, Blue-White shall only be obligated to repair or replace its defective parts or products in accordance with the associated product warranties. **BLUE-WHITE SHALL NOT BE LIABLE EITHER IN TORT OR IN CONTRACT FOR ANY LOSS OR DAMAGE WHETHER DIRECT, INDIRECT, INCIDENTAL, OR CONSEQUENTIAL, ARISING OUT OF OR RELATED TO THE FAILURE OF ANY OF ITS PARTS OR PRODUCTS OR OF THEIR UNSUITABILITY FOR A GIVEN PURPOSE OR APPLICATION.**

### 15.5 CHEMICAL RESISTANCE WARNING

Blue-White offers a wide variety of wetted parts. Purchasers, installers, and operators of Blue-White products must be well informed and aware of the precautions to be taken when injecting or measuring various chemicals, especially those considered to be irritants, contaminants or hazardous. Customers are expected to do their own due diligence regarding which products and materials are best suited for their applications, particularly as it may relate to the potential effects of certain chemicals on Blue-White products and the potential for adverse chemical interactions. Blue-White tests its products with water only. The chemical resistance information included in this instruction manual was supplied to Blue-White by reputable sources, but Blue-White is not able to vouch for the accuracy or completeness thereof. While Blue-White will honor all of its product warranties according to their terms and conditions, Blue-White shall only be obligated to repair or replace its defective parts or products in accordance with the associated product warranties. **BLUE-WHITE SHALL NOT BE LIABLE EITHER IN TORT OR IN CONTRACT FOR ANY LOSS OR DAMAGE, WHETHER DIRECT, INDIRECT, INCIDENTAL, OR CONSEQUENTIAL, ARISING OUT OF OR RELATED TO THE USE OF CHEMICALS IN CONNECTION WITH ANY BLUE-WHITE PRODUCTS.**

## APPENDIX A: ACRONYMS

°C	Celsius	WEEE	Waste Electrical and Electronic Equipment
°F	Fahrenheit		
AC	Alternating current		
bar	Unit of pressure		
CIP	Clean-in-place		
cm	Centimeters		
COD	Cash on Delivery		
D	Depth		
DC	Direct current		
EEE	Electrical and electronic equipment		
EP	Ethylene propylene		
ETL	Electrical Testing Labs/Intertek		
EU	European Union		
FDA	Food and Drug Administration		
FKM	Fluoroelastomer		
FVS	Flow Verification Sensor		
GF	Glass fiber		
GPD	Gallons per day		
H	Height		
Hz	Hertz		
ID	Inside diameter		
IO	Input/Output		
Kg	Kilogram		
lb.	Pound		
LLDPE	Linear low-density polyethylene		
LPH	Liters per hour		
mA	Milliampere		
MSDS	Material Safety Data Sheet		
N.C.	Normally Close		
N.O.	Normally Open		
NPT	National Pipe Thread		
NSF	National Sanitation Foundation		
OD	Outside diameter		
P.N.	Part Number		
PBT	Polybutylene Terephthalate		
PE	Polyethylene		
PSI	Pounds per Square Inch		
PVC	Polyvinyl chloride		
PVDF	Polyvinylidene fluoride		
RCD	Residual-current device		
Rev.	Revision		
RMA	Return Material Authorization		
RPM	Revolutions per minute		
SIP	Steam-in-place		
SS	Solid state		
TFD	Tube Failure Detection		
TFE/P	Tetrafluoroethylene propylene		
UL	Underwriters Laboratories		
US	United States		
V	Volt		
W	Watt		
W	Width		

## Model Number Matrix

### FLEXFLO® Model Number

<b>A1A</b>	FLEXFLO® Peristaltic Metering Pump			
<b>Power Cord</b>				
<b>4</b>	115V 50/60Hz, power cord NEMA 5/15 plug (US) (detachable - 3.9 ft)			
<b>6</b>	220V 50/60Hz, power cord CEE 7/V11 plug (EU) (detachable - 6 ft)			
<b>X</b>	No Power Cord (Power cord is required - See Accessories for power cord options)			
<b>Pump Tube Material, Pump Tube Size, Operating Flow Range</b>				
<b>7T</b>	Flex-A-Prene® .250 ID   .01-100 GPD   40 PSI			
<b>A1A</b>	<b>4</b>	<b>-</b>	<b>7T</b>	Sample Model Number

# Blue-White®

Fluid metering solutions made simple



Users of electrical and electronic equipment (EEE) with the WEEE marking per Annex IV of the WEEE Directive must not dispose of end of life EEE as unsorted municipal waste, but use the collection framework available to them for the return, recycle, recovery of WEEE and minimize any potential effects of EEE on the environment and human health due to the presence of hazardous substances. The WEEE marking applies only to countries within the European Union (EU) and Norway. Appliances are labeled in accordance with European Directive 2002/96/EC.

Contact your local waste recovery agency for a *Designated Collection Facility* in your area.

5300 Business Drive  
Huntington Beach, CA 92649  
USA

TEL: 714-893-8529  
FAX: 714-894-9492

[www.blue-white.com](http://www.blue-white.com)  
[customerservice@blue-white.com](mailto:customerservice@blue-white.com)