

# CHEM-FEED<sup>®</sup>

Diaphragm Metering Pump



## Series MD3

<b>1.0</b>	<b>Introduction</b>	<b>4</b>
	1.1 Specifications	4
	1.2 Materials of Construction	4
	1.3 Features	5
	1.4 Agency Listings	5
<b>2.0</b>	<b>Installation</b>	<b>6</b>
	2.1 Mounting Location	6
	2.2 Product Dimensions	7
	2.3 Input Power Connections	8
	2.4 Wiring Terminals and I/O Schematics	9
<b>3.0</b>	<b>How to Operate MD3</b>	<b>10</b>
	3.1 Priming and Running the Pump	11
	3.2 Menu Navigation	11
	3.3 Configuration Menu	12
	3.3.1 Language Selection	12
	3.3.2 Display Rate (units of measure)	13
	3.3.3 Reset Factory Defaults	13
<b>4.0</b>	<b>Input Setup</b>	<b>14</b>
	4.1 Max RPM Cut-off	15
	4.2 Max Flowrate (Output Calibration)	15
	4.3 Input Setup (Operating Mode Configuration)	16
	4.3.1 Manual Adjust (manual speed adjust)	16
	4.3.2 4 - 20 mA Input	17
	4.3.3 0 - 10 VDC Input	18
	4.3.4 Frequency Input (Hz)	19
	4.3.5 Pulse Batch (low speed batch)	20
	4.3.6 Manual Cycle Adjust (repeating cycle timer)	21
	4.3.7 Dispensing	22
	4.3.8 Manual Dosing	23
	4.3.9 Proportional Dosing	24
	4.4 Contact Closure Input (Remote start/stop)	25
	4.5 Set FVS (Flow Verification System)	26
	4.6 DFD (Diaphragm Detection System)	27
	4.7 Remote/Local Control	28
	4.8 Set Revolution Alarm	28
<b>5.0</b>	<b>Output Setup (Alarm Relays &amp; Output Signal signals)</b>	<b>29</b>
	5.1 Signal Output	30
<b>6.0</b>	<b>Pump Maintenance</b>	<b>31</b>
	6.1 Routine Inspection and Maintenance	31
	6.2 How to Clean the Pump	31
	6.3 Replacing the Pump Diaphragm	31
<b>7.0</b>	<b>Exploded View and Parts list</b>	<b>32</b>
<b>8.0</b>	<b>Output versus Pressure</b>	<b>34</b>
<b>9.0</b>	<b>Warranty</b>	<b>38</b>
<b>10.0</b>	<b>Model Number Matrix</b>	<b>39</b>

**READ THE INSTRUCTION MANUAL PRIOR TO INSTALLATION AND USE.**



+1 (714) 893 - 8529



[sales@blue-white.com](mailto:sales@blue-white.com)



[customerservice@blue-white.com](mailto:customerservice@blue-white.com)



5300 Business Drive  
Huntington Beach, CA 92649



### 1.3 Features

Motor driven diaphragm pump offers smooth and quiet chemical dosing. No hard pulses as seen with solenoid driven pumps.

2,000:1 turndown ratio.

Full stroke every time avoids vapor lock.

Brushless DC motor.

Rated for continuous duty (24/7).

Exclusive DIAFLEX® Diaphragm guaranteed to last the life of the pump.

PVDF / Ceramic pump head components.

Diaphragm Failure Detection (DFD) system. Senses diaphragm failure by detecting chemical in pump head.

VGA Graphic multi-color backlit LCD displays remote/local control status, motor speed, output rate, input signal values, service and alarm status in three easy to see colors.

Outputs include: Scalable 4-20mA or pulse, one 250V/6A relay and three 115V/1A contact closures assignable to monitor various pump functions including DFD, FVS, revolution counter, remote/local, input signals, output signals, motor on, motor fault, operating mode setting, and others.

CNC precision machined cam and piston for optimum efficiency, unparalleled accuracy, and linearity.

Heavy duty PVDF pump head and valves are standard.

Compatible with Blue-White's output Flow Verification Sensor (FVS) system.

Includes stainless steel extended mounting brackets. Lifts pump 4-1/2" (11.43 cm), for easy access in hard to reach areas.

#### Enclosure Rating:

**NEMA 4X:** Constructed for either indoor or outdoor use to provide a degree of protection to personnel against incidental contact with enclosed equipment; to provide a degree of protection against falling dirt, rain, sleet, snow, windblown dust, splashing water, and hose-directed water; and that will be undamaged by external formation of ice on enclosure.

**IP66:** No ingress of dust; complete protection against contact. Water projected in powerful jets against enclosure from any direction shall have no harmful effects.

### 1.4 Agency Listings



This pump is certified to NSF/ANSI Standard 61 - Drinking Water System Components - Health Effects



This pump is ETL listed to conform to the following:  
UL Standard 778 as a motor operated water pump  
CSA Standard C22.2 as process control equipment



This pump complies to the Machinery Directive 2006/42/EC, BS, EN 60204-1, Low Voltage Directive 2014/35/EU BS EN 61010-1, EMC Directive 2014/30/EU, BS EN 50081-1/BS EN 50082-1.

Symbol	Explanation
	WARNING, risk of electric shock
	CAUTION, refer to users' guide
	GROUND, protective conductor terminal

## 2.0 Installation

**CAUTION**

Always wear protective clothing, face shield, safety glasses and gloves when working on or near your metering pump. Additional precautions should be taken depending on solution being pumped. Refer to MSDS precautions from your solution supplier.

**CAUTION**

All diagrams are strictly for guideline purposes only. Always consult an expert before installing metering pump on specialized systems. Metering pump should be serviced by qualified persons only.

---

## 2.1 Mounting Location

Choose an area located near chemical supply tank, chemical injection point, and electrical supply. Install pump where it can be easily serviced.

316SS Mounting brackets are included. Mount pump to a secure surface using enclosed mounting hardware.

Mount pump close to injection point. Keep inlet (suction) and outlet (discharge) plumbing as short as possible. Longer discharge plumbing increases back pressure at pump head.

Install a back flow prevention check valve at discharge side of pump to prevent system fluid from flowing back through pump during pump maintenance.

A pressure relief valve is recommended at discharge of pump.

Bolt pump to a stable surface.

## 2.2 Dimensions

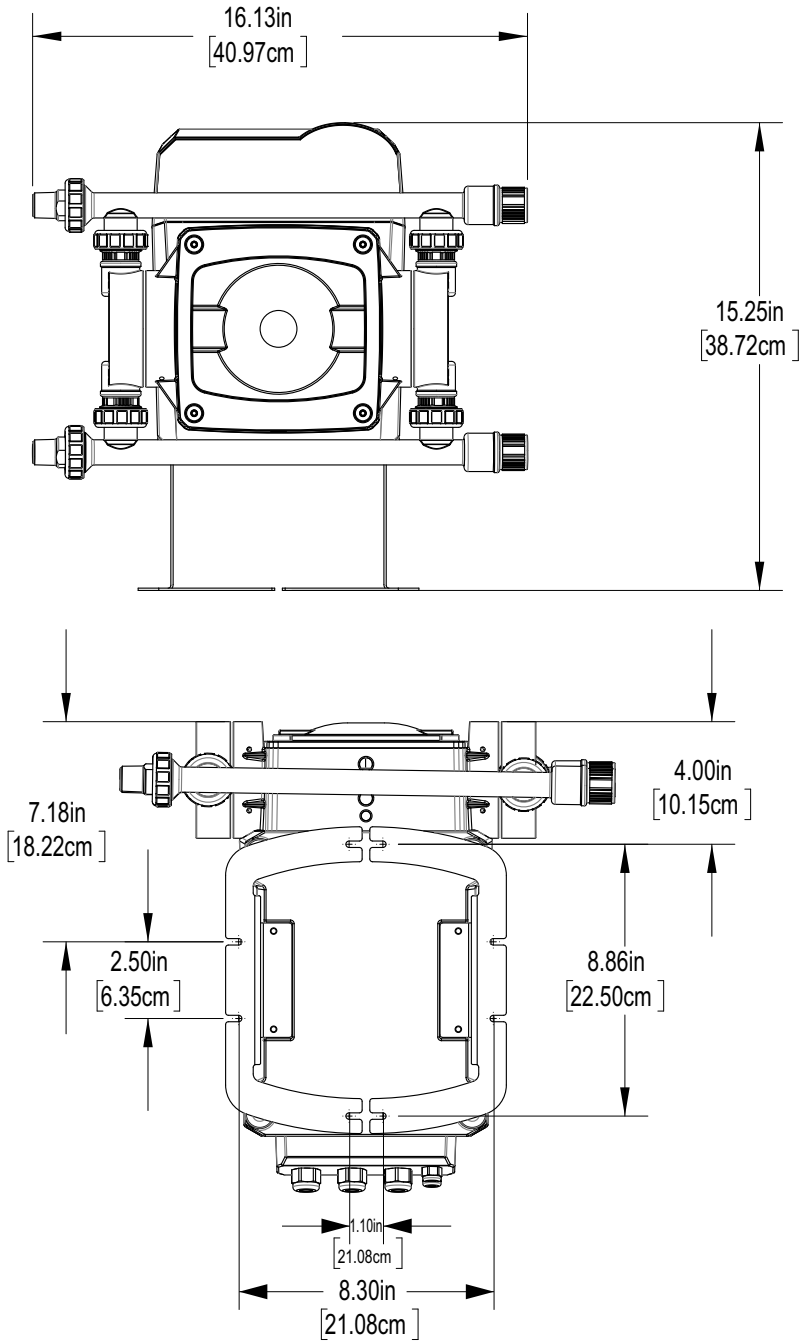



### Extended Brackets

Stainless Steel extended brackets allow the pump to be securely mounted to most any surface; floor, shelf, or skid.

- Made out of tough Stainless Steel.
- Provides a stable mounting surface.



## 2.3 Input Power Connections

<b>WARNING</b> 	Risk of electric shock – cord connected models are supplied with a grounding conductor and grounding-type attachment plug. To reduce risk of electric shock, be certain that it is connected only to a properly grounded, grounding-type receptacle.
<b>WARNING</b> 	Electrical connections and grounding (earthing) must conform to local wiring codes. Be certain that a grounding conductor is connected to terminal T11-1 located in the wiring compartment.
<b>WARNING</b> 	Risk of electric shock - Disconnect electricity before removing the wiring compartment cover.

- ! Be certain to connect pump to proper supply voltage. Using incorrect voltage will damage pump and may result in injury. Voltage requirement is printed on pump serial label.
- ! Input power range is 100VAC to 240VAC 50/60 Hz.
- ! Voltage Selection is automatically detected and adjusted by power supply. No mechanical switch necessary.
- ! Use voltage your power cord is rated for.
- ! Cord connected models are supplied with a ground wire conductor and a grounding type attachment plug (power cord). To reduce risk of electric shock, be certain that power cord is connected only to a properly grounded, grounding type receptacle.
- ! Permanently connected models must be properly grounded. Be certain that a grounding conductor is connected to terminal T11-1 located in the wiring compartment.
- ! Wiring compartment access requires removing 4 screws. A 5/32" (.156") allen wrench is required (included).
- ! Be sure all wiring compartment cable glands and hole plugs are properly installed and sealed.
- ! Never strap control (input / output) cables and power cables together.
- ! **Power Interruption:** This pump has a user programmable auto-restart feature which will either restore the pump to the operating state it was in when power was lost or require a user action to restart.

**Note:** When in doubt regarding your electrical installation, contact a licensed electrician.

### WIRING COMPARTMENT COVER

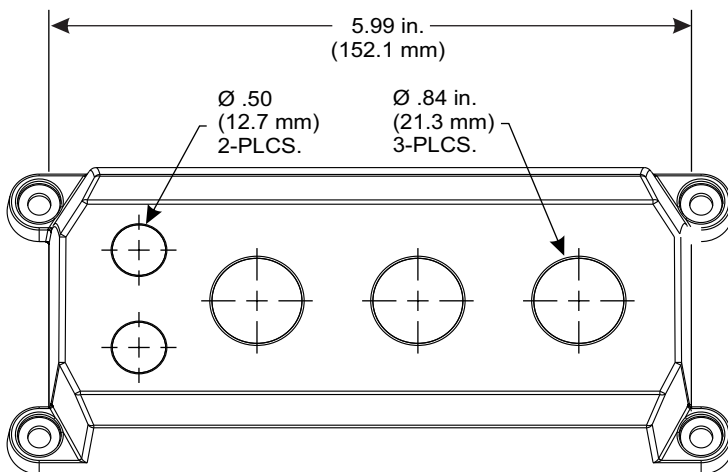

### Cable and conduit connectors included

### POWER CORD OPTIONS

Three power cord plug types available.  
Power cord length is 6 feet (3.83 meters)



115V 60Hz  
NEMA 5/15 (USA)  
max: 125V AC

230V 60Hz  
NEMA 6/15 (USA)  
max: 250V AC

240V 50Hz  
CEE 7/VII (EU)  
max: 250V AC

### QTY. DESCRIPTION

- |   |  |
|---|--|
| 2 | .50 INCH (12.7 mm) LIQ-TIGHT HOLE PLUGS (MAT'L = NEOPRENE), PRE-INSTALLED  |
| 3 | .875 INCH (22.2 mm) LIQ-TIGHT HOLE PLUGS (MAT'L = NEOPRENE), 2 PRE-INSTALLED   |
| 2 | .50 INCH (12.7 mm) LIQ-TIGHT CONNECTORS FOR PASS THRU CORDS (MAT'L = NYLON)<br>ACCEPTABLE CABLE DIAMETER .118 TO .255 INCH (3.0 TO 6.5 MM), NOT INSTALLED                                      |
| 3 | .875 INCH (22.2 mm) METALLIC LIQ-TIGHT CONNECTORS FOR PASS THRU CORDS (MAT'L = NYLON)<br>ACCEPTABLE CABLE DIAMETER .200 TO .395 INCH (5.1 TO =10.0 MM), 1 PRE-INSTALLED WITH POWER CORD MODELS |
| 2 | METALLIC LIQ-TIGHT CONNECTORS FOR .50 INCH FLEXIBLE CONDUIT (MAT'L = DIE CAST ZINC), NOT INSTALLED   |



### 2.4 Wiring Terminals and I/O Schematics

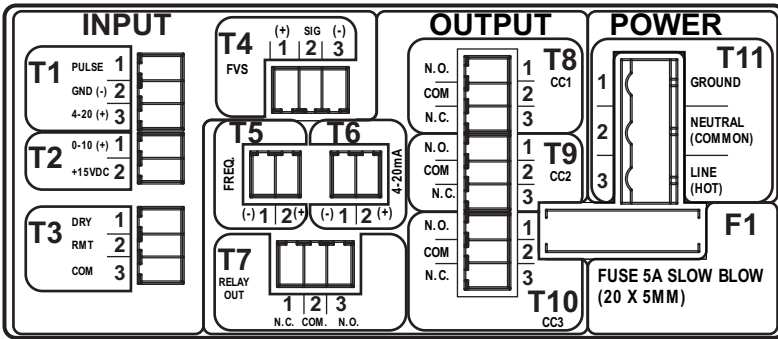

**WARNING**  
Risk of electric shock - All wiring must be insulated and rated 300V minimum.

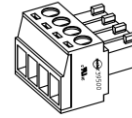

Terminals T1 thru T10  
Plug type  
16 - 24 AWG

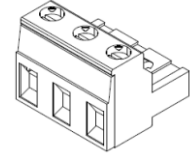

Power Input Terminal T11  
Plug type  
14 - 30 AWG

Shielded cables should be used on all input signal wires.

FUNCTION	TERMINAL	PIN #	RATING	ELECTRICAL SP.	BLOCK DIAGRAM
INPUT: 4-20 mA	T1	3	(+) POSITIVE	120 OHM IMPEDANCE, NON POWERED LOOP	
	T1	2	(-) NEGATIVE		
INPUT: FREQUENCY, AC SINE WAVE, TTL, CMOS	T1	1	(+) POSITIVE	0-1000 HZ MAX.	
	T1	2	(-) NEGATIVE		
INPUT: 0-10V DC	T2	1	(+) POSITIVE		
	T1	2	(-) NEGATIVE		
INPUT: FVS SYSTEM (FLOW VERIFICATION SENSOR) FV SENSOR ONLY	T4	1	(+) POSITIVE		
	T4	2	SIGNAL		
	T4	3	(-) NEGATIVE		
INPUT: FVS SYSTEM (FLOW VERIFICATION SENSOR) FS or FP MICRO-FLO FLOWMETER ONLY	T4	1	(+) POSITIVE		
	T4	2	SIGNAL		
	T4	3	(-) NEGATIVE		
INPUT: REMOTE START / STOP (DRY CONTACT C.)	T3	1	(-) NEGATIVE	NO VOLTAGE	
	T3	2	(+) POSITIVE		
INPUT: REMOTE START / STOP (WET CONTACT C.)	T3	2	(+) POSITIVE	3 TO 30 VOLT DC 1 AMP MAX.	
	T3	3	(-) NEGATIVE		
OUTPUT: 4-20 mA	T6	2	(+) POSITIVE	120 OHM RESISTANCE ACTIVE LOOP	
	T6	1	(-) NEGATIVE		
OUTPUT: FREQUENCY - OPEN COLLECTOR	T5	2	(+) POSITIVE	OPEN COLLECTOR 0-1000 HZ 50% DUTY CYCLE	
	T5	1	(-) NEGATIVE		
OUTPUT: RELAY, 6 AMP	T7	1	NORM. CLOSED	Form C 6 AMP MAX AT 250 VAC, 5 AMP MAX AT 30 VOLT DC	
	T7	2	COMMON		
	T7	3	NORM. OPEN		
OUTPUT: CONTACT CLOSURE 1	T8	1	NORM. OPEN	Form C 1 AMP MAX AT 125 VOLT AC, 0.8 AMP MAX AT 30 VOLT DC	
	T8	2	COMMON		
	T8	3	NORM. CLOSED		
OUTPUT: CONTACT CLOSURE 2	T9	1	NORM. OPEN	Form C 1 AMP MAX AT 125 VOLT AC, 0.8 AMP MAX AT 30 VOLT DC	
	T9	2	COMMON		
	T9	3	NORM. CLOSED		
OUTPUT: CONTACT CLOSURE 3	T10	1	NORM. OPEN	Form C 1 AMP MAX AT 125 VOLT AC, 0.8 AMP MAX AT 30 VOLT DC	
	T10	2	COMMON		
	T10	3	NORM. CLOSED		
INPUT: POWER	T11	1	GROUND	96 TO 264 VOLT AC, 50 / 60 HZ MD3 = 220W	
	T11	2	NEUTRAL		
	T11	3	LINE (HOT)		
FUSE	F1	NA	5 AMP	5A SLOW BLOW (20 X 5MM)	

**NOTE:** USE ONLY DRY CONTACT FOR REMOTE S/S WHEN USING 4-20mA INPUT OR 0-10V DC

### 3.0 How To Operate MD3

#### MD3 Control Panel - Button Operation



**Press and release** to select a Run Mode.  
**Press and hold** to enter the configuration menu for the currently active run mode only.

**Press and release** to prime the pump.

**Press and release** to activate light.

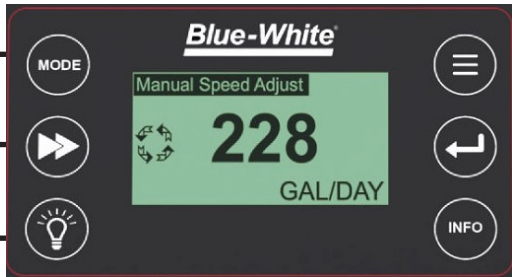

**Press and release** to enter the configuration menus.

**Press and release** to confirm a menu selection.

**Press and release** to view revolution counter data.

**Press and release** to select menu items, increase menu values by one, and increase pump output in *Manual Speed Adjust* mode.  
**Press and hold** to increase values progressively faster.

**Press and release** to start the pump.

**Press and release** to stop the pump.

**Press and release** to select menu items, decrease menu values by one, and decrease pump output in *Manual Speed Adjust* mode.  
**Press and hold** to decrease values progressively faster.

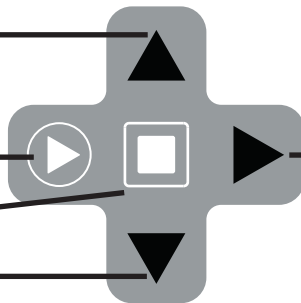

**Press and release** to select menu items.

**Press and release** (when not in the configuration menu) to toggle the display units of measure and to display the current input signal values

### 3.1 Priming and Running the Pump

When first starting pump, or after maintenance when solution is drained from piping, the pump will need to be primed. Press the Prime button to initiate priming. The pump will run at 100% speed for 60 seconds. Press the Stop button to stop the pump at any time during priming.

Priming will fill the suction and discharge tubing/piping and ensure the pump will inject into the desired feed location when it is started. Priming the pump can also be useful when expelling any gasses built up in the system after a period of non-use.

After priming, the pump is ready to run. Press the Start button to run the pump in Manual Mode. For other operating modes, refer to instructions in that section of the manual to run the pump.

If using a contact closure to active the pump, be aware that pressing the Start button will either put the pump in "Ready Mode" waiting for a signal/closure, or the pump may start running if the contact closure is already active.

Regardless of the operating mode, pressing the Stop button will always stop the pump.

### 3.2 Menu Navigation

Use MENU button to enter menu for setting up pump.

Use UP or DOWN arrows to navigate through menu.

Active option appears on pump display in **inverse** text.

Plus symbol **+** signifies top of a menu tree. This means you can go further within the menu.

Within the Menu of the pump, each screen you enter will have a title located along the top. This will display the menu that is currently active, or this will be the setting you are configuring.

To back out of menu, select **<- Esc** line located at end of the list. Then press ENTER button. This will take you back one level.

When the menu list extends above or below height of display, a scroll bar will appear on left side. Press DOWN arrow to scroll down to the end of the list to see a list of all the available options.

Scroll bar example:



While making a selection where only one choice is allowed, you will see a radio button.

Radio button example:  Solid black means item is selected  
 Outline with no fill means item is not selected

In a screen where you are making changes, you will see the word **Done** located at the bottom of the list. You must select **Done** in order to leave the screen (whether you made a change or not). Selecting **Done** will take you back to the parent level.

When inputting a numerical value, use UP or DOWN arrow to scroll through 0 - 9. To move over to the next digit use RIGHT arrow. If you pass your desired digit, you can continuously press RIGHT arrow until you reach your desired digit.

Numeric value example:

– Sample screen shots –

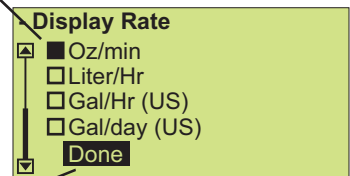
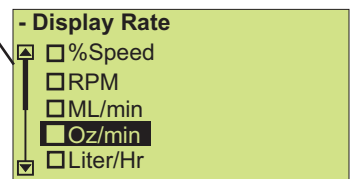
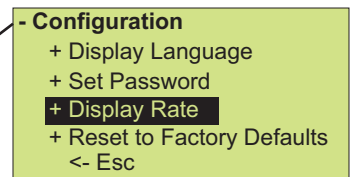
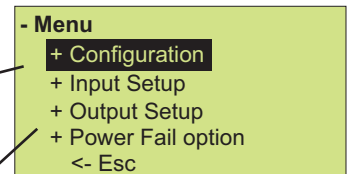

### 3.3 Configuration Menu

Below is the menu structure for the Configuration screens.

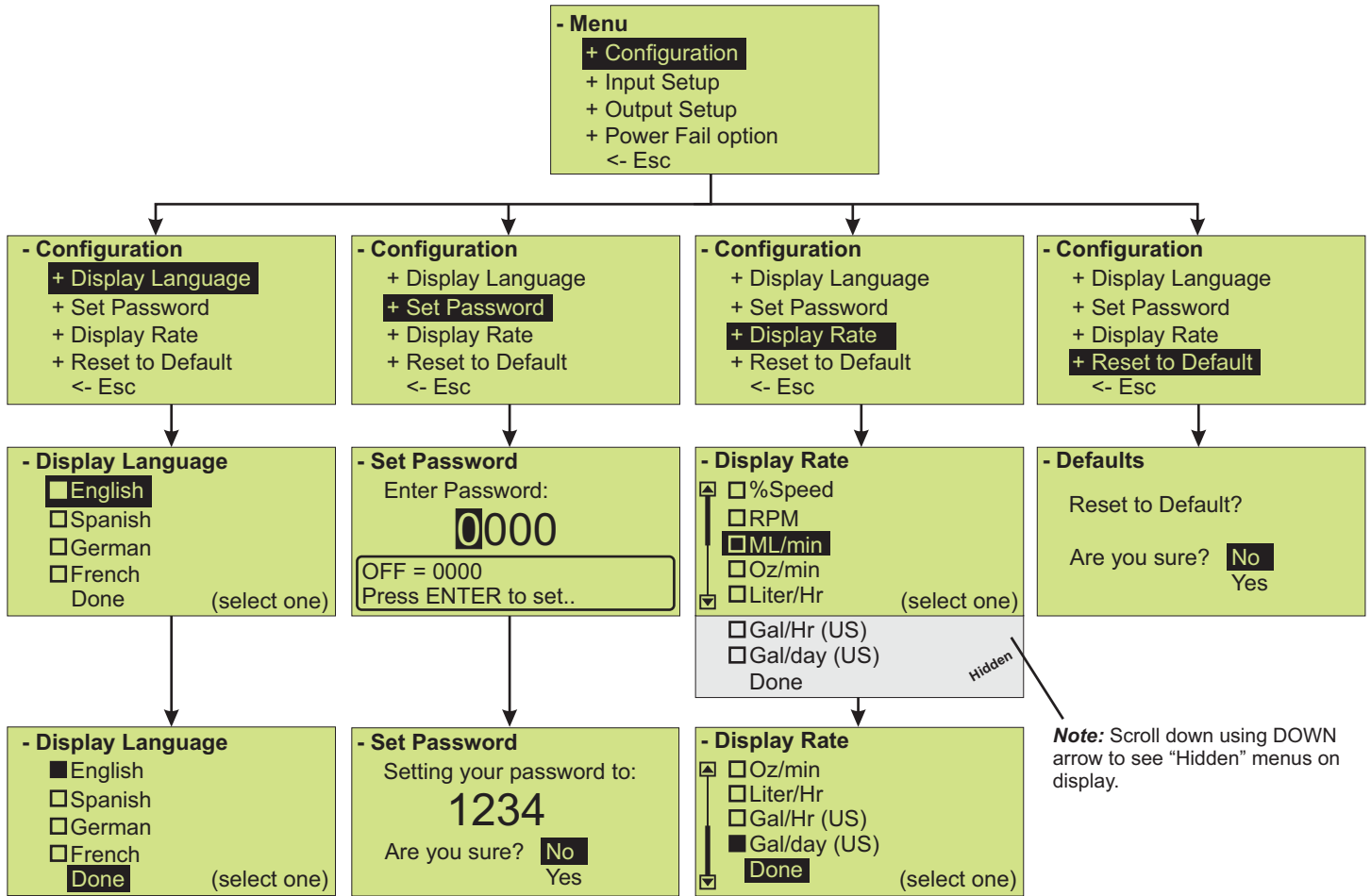

#### 3.3.1 Language Selection

Press MENU button to enter the menu structure.

Select **Configuration** and Press ENTER button.

Select **Display Language** and Press ENTER button.

Select your desired language, then Press ENTER.

*Note:* English is the default language.

Select **Done** at bottom of list to confirm your selection. Press ENTER button.

Select **<-Esc** on the main menu screen to exit the menu structure and enter the run mode.

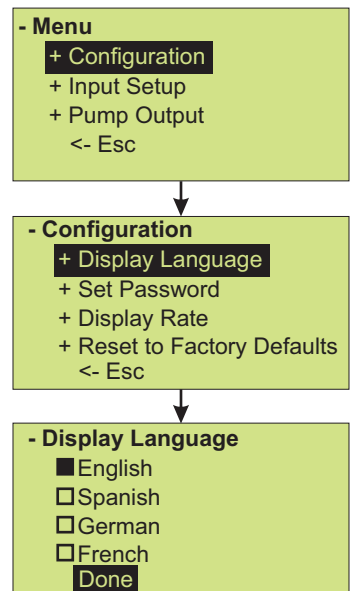

### 3.3.2 Display Rate (Units of Measure)

By default, the pump will display %Speed (motor speed) and RPM. It is recommended you select an additional **Display Rate**. After selecting another **Display Rate** (such as ML/Min), the pump display may be toggled through %Speed, RPM and your selected Display Rate by pressing the right arrow button.

Press MENU button to enter the menu structure.

Select **Configuration** and Press ENTER button.

Select **Display Rate** and Press ENTER button.

Select your desired Display Rate (unit of measure). Note: %Speed and RPM will always be active and available to view while pump is in operation.

Select **Done** at the bottom of the list to confirm your selection and to return back to the previous screen. Press ENTER button.

Select **<-Esc** on the main menu screen to exit the menu structure and enter the run mode.

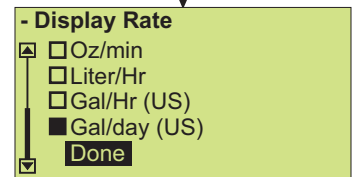
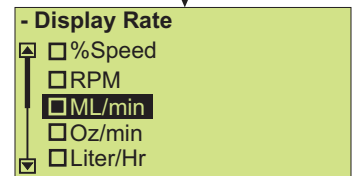
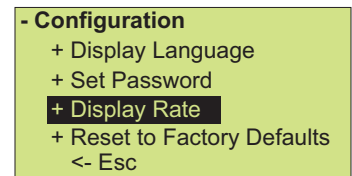

#### Tip!



While pump is operating in any Run Mode, press RIGHT arrow to scroll through multiple read-only screens including output rate and input signal values.

**Note:** This is a read-only feature, no changes can be made while in Run Mode.

### 3.3.3 Reset Factory Defaults

This will reset pump to the factory defaults. This will restore the pump to the original configuration when it left the factory.

Press MENU button to enter menu structure.

Select **Configuration** and Press ENTER button.

Select **Reset to Factory Defaults** and Press ENTER button.

Select **No** or **Yes**, then ENTER button.

Select **<-Esc** on the main menu screen to exit the menu structure and enter the run mode.

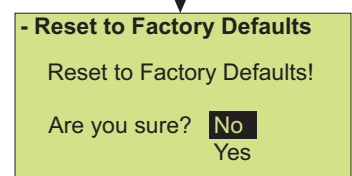
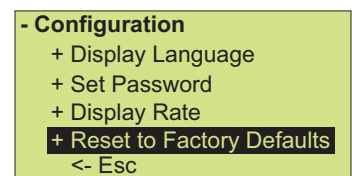

## 4.0 Input Setup

Below is the menu structure for the INPUT SETUP selection.

### Max RPM cut-off - 4.1

To Select a maximum motor RPM. Input the maximum RPM value.

### Max Flowrate - 4.2

To calibrate your pump. This setting is pre-configured at the factory. Pump has been calibrated with water. You can re-calibrate pump. Input the calibrated MLI/min at 100% motor speed.

### Input Modes - 4.3

To configure your pump's Run Modes. Use this menu to setup your desired operating mode. This manual will cover each step in detail later.

### Contact Input - 4.4

(remote start/stop)  
Contact Closure Input feature is used to Start and Stop pump remotely. Default setting is DISABLE.

### Set FVS - 4.5

(Flow Verification System)  
Set Flow Verification time delay. Use this feature if you are using a Blue-White flow verification sensor to monitor flow output. Default setting is OFF.

### Set DFD - 4.6

(Diaphragm Failure Detection)  
Set Diaphragm Failure Detection sensitivity. Use this feature to increase the sensitivity to your chemical. Default setting is 75%.

### Set Remote/Local control - 4.7

(Control panel touch pad lockout)  
Select remote to disable the touch pad buttons enabling input signal control only. When remote is selected, the user must select an input operating mode. Select Local to disable all input signals and allow local touch pad control only.

### Set Revolution Alarm - 4.8

(number of cam revolutions)  
Set the number of revolutions required to trigger the display alarm (display turns red) and to trigger the output contact closure.

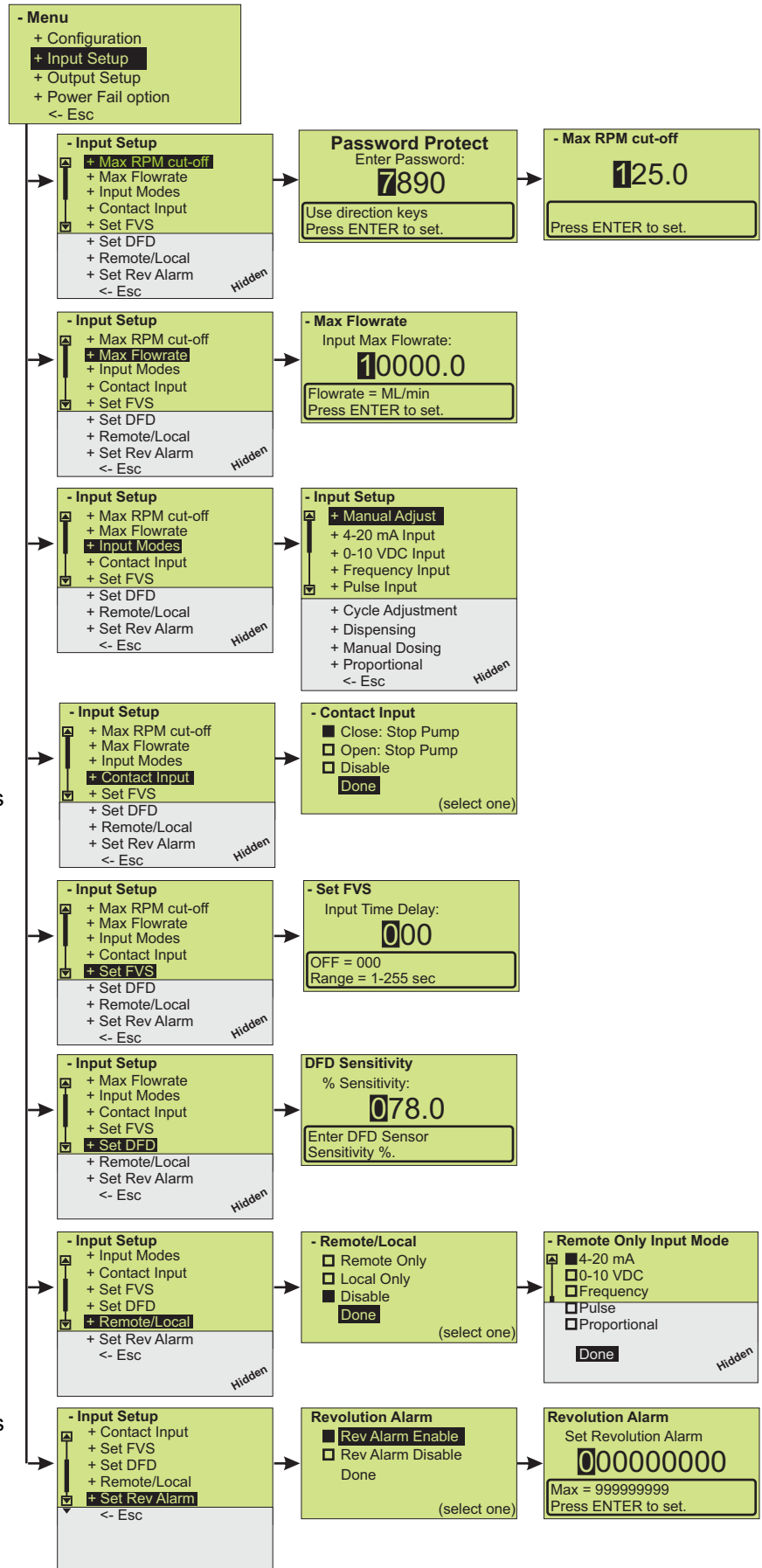

## 4.1 Max RPM cut-off

The maximum motor RPM can be limited to reduce the possibility of overfeeding chemical into the system. Note that the pump's display will still reference values calculated from the 100% motor speed MAX Flowrate value (see section 4.2). Also, the pump % motor speed will still be referenced from 190 RPM, the maximum possible motor RPM. For example, if the pump speed is set for 25%, the display will indicate 47.5 RPM. The prime mode RPM is limited to the Max RPM value.

Select **Max RPM cut-off** and Press ENTER button. Use the direction arrows to enter the password 7890.

Press UP or DOWN arrow to scroll through 0 - 9 on selected digit.

Press RIGHT arrow to scroll over to next digit to right. If you pass your desired digit, you can easily scroll back by continuously pressing RIGHT button.

Press ENTER to save changes.

Select **<-Esc** on the main menu screen to exit the menu and enter the run mode.

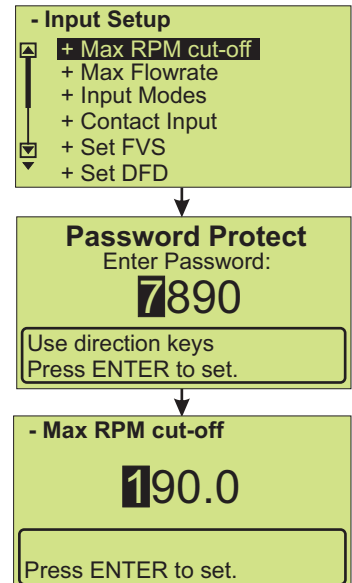

## 4.2 MAX Flowrate (output calibration)

The MAX Flowrate value is equal to the pump's measured fluid output in milliliters per minute, at the 100% motor speed adjustment setting. The pump uses the MAX flow rate value to calculate motor speed for various operating functions and to display output values.

The MAX flow rate value can be adjusted at any time. To achieve high accuracy, a field calibration under the actual operating conditions should be performed and the Max Flowrate value changed to reflect the calibrated amount. Multiply the **Max Flowrate** value by the percentage of error at your calibrated flow rate to obtain the new **Max Flowrate** value.

Select **Max Flowrate** and Press ENTER button.

Press UP or DOWN arrow to scroll through 0 - 9 on selected digit.

Press RIGHT arrow to scroll over to next digit to right. If you pass your desired digit, you can easily scroll back by continuously pressing RIGHT button.

Press ENTER to save changes.

Select **<-Esc** on the main menu screen to exit the menu structure and enter the run mode.

NOTE: Your actual output may vary due to fluid viscosity, fluid temperature, suction lift height, piping system layout, manufacturing tolerances and to a lesser degree, and variations in system pressure.

To achieve high accuracy, the pump's output should be measured (calibrated), and the MAX Flowrate value (in milliliters per minute) updated, whenever any of the following conditions exist:

- At the initial pump start up.
- When the piping system configuration is changed.
- When the suction lift height is changed.

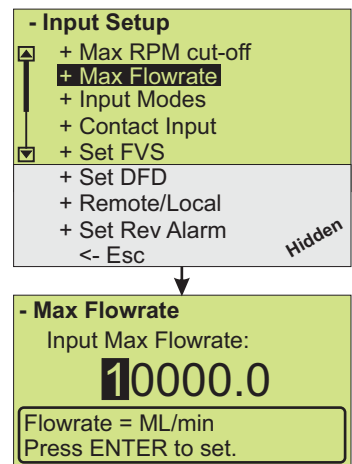

### To calculate the Max Flowrate:

To determine the amount of error at your output setting, divide the actual output amount by the indicated output. Then multiply the resulting percentage of error by the **Max Flowrate** value currently showing in the pump.

Example: If the pump display indicates the output is 170 ml/min but the actual measured output is 160 ml/min, calculate the percentage of error by:  $160/170 = 0.941$ . Multiply the **Max Flowrate** value by 0.941 and enter this new value.

### 4.3 Input Setup (operating mode configuration)

#### Tip!

MODE button also serves as a shortcut button.  
**Press and Hold** MODE button to enter the programming menu for the current Run Mode. After programming the Run Mode, press ENTER to save changes. **Press and Hold** MODE button to exit the program menu back to the current Run Mode of the pump.  
**Press** START button to start the pump with the new settings applied.

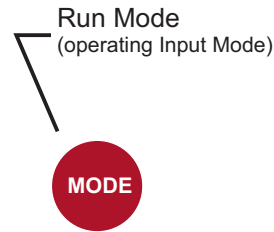

#### 4.3.1 Manual Adjust (manual speed adjust)

Used to manually control the speed of pump. Set % (percent) Motor Speed in this menu.

Press SELECT RUN MODE button until **Manual Speed Adjust** is displayed in the top line of the display.

To configure the pump output speed, navigate to **Manual Speed Adjust** menu by using the short-cut method described above, or by pressing MENU button, then selecting Input Setup, Input Modes, and then **Manual Adjust**.

Press UP or DOWN arrow to scroll through 0 - 9 on selected digit.

Press RIGHT arrow to scroll over to next digit to right. If you pass your desired digit, you can easily scroll back by continuously pressing RIGHT button.

Press ENTER to save changes.

If you used the short-cut to enter Manual Speed Adjust setup, press and hold the Select Run Mode button until the Run Mode screen is displayed.

If you used the Menu button to navigate to the Manual Speed Adjust setup, you must navigate back out of the menu structure. To do this you must select <-Esc at the bottom of every screen menu until you see the Run Mode screen displayed.

**Tip!** The **Manual Speed Adjust** mode can be combined with **Contact Input** feature to allow for remote Start and Stop of pump. Can be used with PLC, foot pedal, push button, or other external controls.

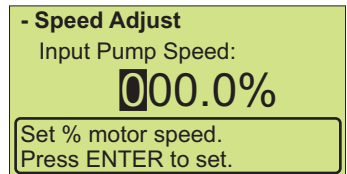

#### Tip!



In Manual Speed Adjust mode, you can view the pump output by pressing RIGHT arrow. RIGHT arrow is a convenient way to scroll through multiple read-only screens during normal pump operation.

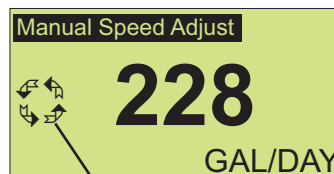

Displays motor run status



### 4.3.2 4 - 20 mA Input

Used to remotely control the pump with an incoming 4-20 mA signal.

Default settings: 4 mA = 0% motor speed  
20 mA = 100% motor speed

Press MODE button until **4 - 20 mA Input** is displayed in the top line of the display.

To configure the pump, navigate to **4 - 20 mA Input** menu by using the short-cut method described at the beginning of section, or by pressing MENU button, then selecting Input Setup, Input Modes, and then **4 - 20 mA Input**

Four points on the slope must be defined; 1) a low mA value, 2) an output rate at the low mA value, 3) a high mA value, and 4) an output rate at the high mA value.

To input mA values, press the RIGHT ARROW to select the digit to change, press UP or DOWN arrow to scroll through 0 - 9 on selected digit. Press enter to save changes and move to the next input screen.

To input flow rate values, press the RIGHT ARROW to select the user defined flow rate unit of measure, motor RPM, or %Speed values. Press UP or DOWN arrow to increase or decrease the value. Press and hold the arrow to increase or decrease progressively faster. Press enter to save changes and move to the next input screen.

Continue this process until all four screens have been configured.

If you used short-cut to enter 4-20 mA input setup, press and hold the Mode button until the Run Mode screen is displayed.

If you used Menu button to navigate to 4-20 mA input setup, you must navigate back out of menu structure. To do this you must select <-Esc at bottom of every screen menu until you see Run Mode screen displayed.

**Note: The pump is designed to fail safe. If the input signal drops below 3.0 mA, the pump assumes a lost signal and the motor speed is set to 0 RPM.**

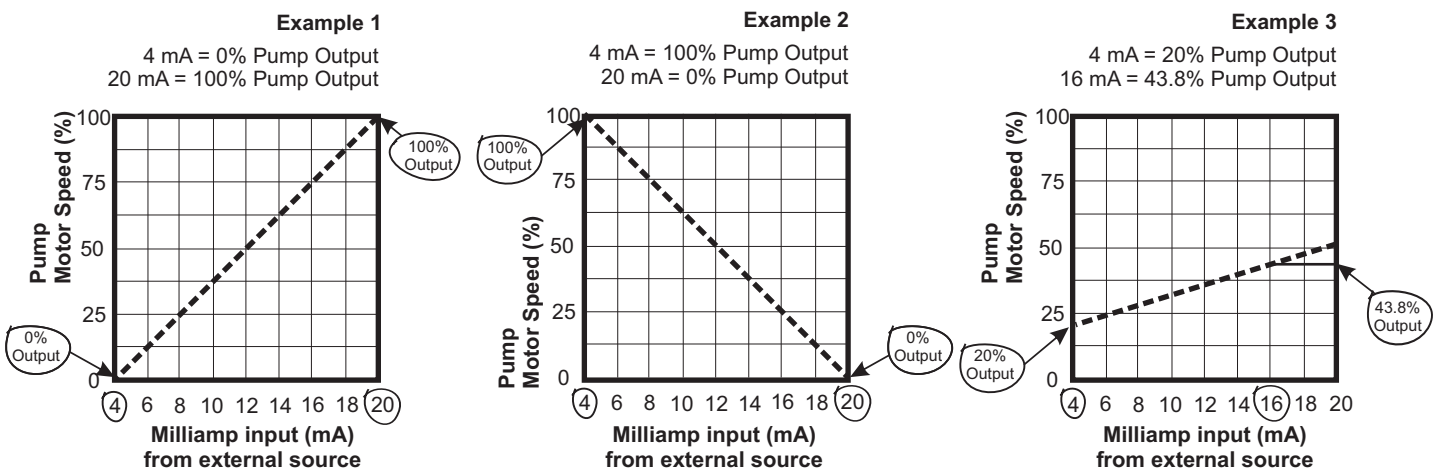
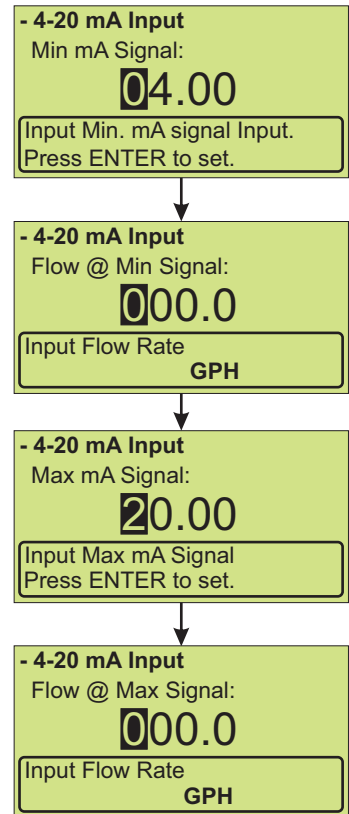

### 4.3.3 0 - 10 VDC Input (Volt DC)

Used to remotely control the pump with an incoming 0-10 VDC signal.

Default settings: 0 VDC = 0% motor speed  
10 VDC = 100% motor speed

Press MODE button until **0 - 10 VDC Input** is displayed in the top line of the display.

To configure the pump, navigate to **0 - 10 VDC Input** menu by using the short-cut method described at the beginning of the section, or by pressing MENU button, then selecting Input Setup, Input Modes, and then **0 - 10 VDC Input**.

Four points on the slope must be defined; 1) a low VDC value, 2) an output rate at the low VDC value, 3) a high VDC value, and 4) an output rate at the high VDC value.

To input VDC values, press the RIGHT ARROW to select the digit to change, press UP or DOWN arrow to scroll through 0 - 9 on selected digit. Press enter to save changes and move to the next input screen.

To input flow rate values, press the RIGHT ARROW to select the user defined flow rate unit of measure, motor RPM, or %Speed values. Press UP or DOWN arrow to increase or decrease the value. Press and hold the arrow to increase or decrease progressively faster. Press enter to save changes and move to the next input screen.

Continue this process until all four screens have been configured.

If you used the short-cut to enter 0 - 10 VDC Input setup, press and hold Mode button until Run Mode screen is displayed.

If you used the Menu button to navigate to 0 - 10 VDC Input setup, you must navigate back out of menu structure. To do this you must select <-Esc at bottom of every screen menu until you see Run Mode screen displayed.

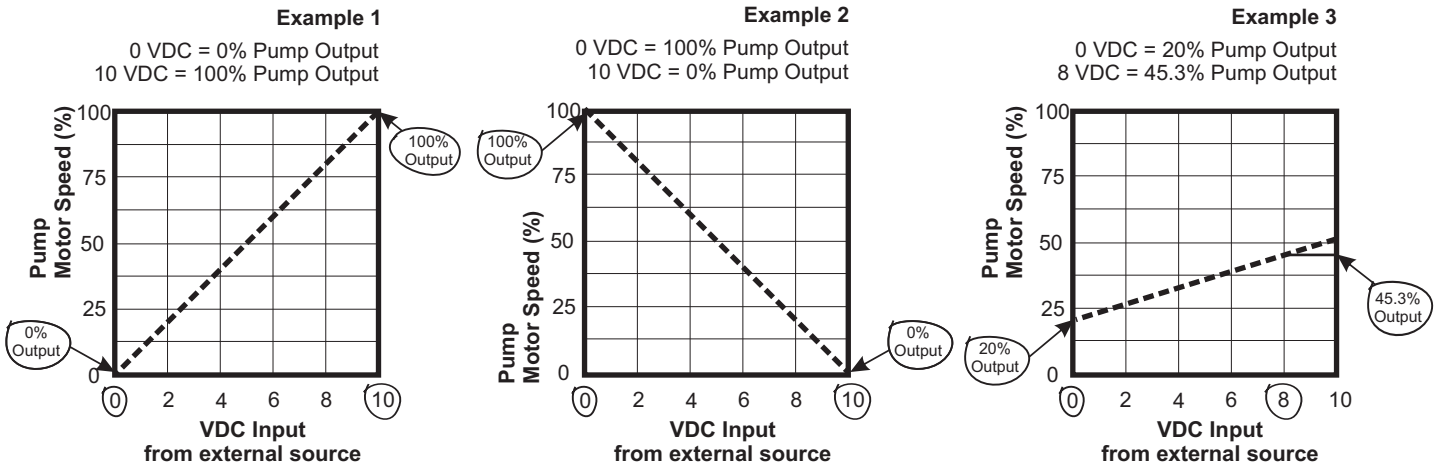
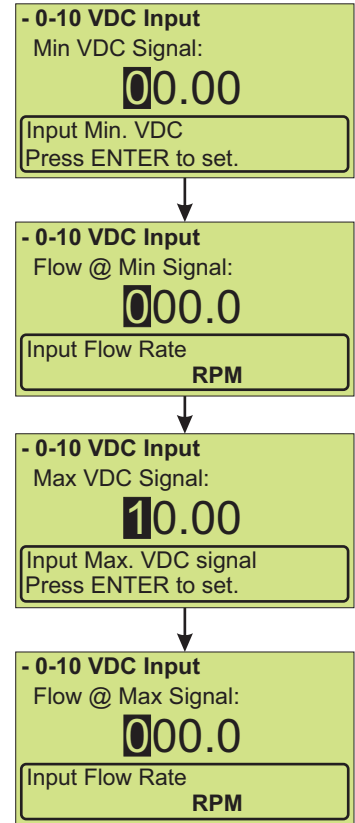

**Tip!** When in the run mode, you can view the current pump output speed and input signal values by pressing the RIGHT arrow.

### 4.3.4 Frequency Input (Hz)

Used to remotely control the pump with an incoming high speed frequency signal. Typically used with flow meters or other external devices.

Default settings: 0 Frequency (Hz) = 0% motor speed  
1000 Frequency (Hz) = 100% motor speed

Press MODE button until **Frequency Input** is displayed in the top line of the display.

To configure the pump, navigate to **Frequency Input** menu by using the short-cut method described at the beginning of section, or by pressing MENU button, then selecting Input Setup, Input Modes, and then **Frequency Input**.

Four points on the slope must be defined; 1) a low Hz value, 2) an output rate at the low Hz value, 3) a high Hz value, and 4) an output rate at the high Hz value.

To input Hz values, press the RIGHT ARROW to select the digit to change, press UP or DOWN arrow to scroll through 0 - 9 on selected digit. Press enter to save changes and move to the next input screen.

To input flow rate values, press the RIGHT ARROW to select the user defined flow rate unit of measure, motor RPM, or %Speed values. Press UP or DOWN arrow to increase or decrease the value. Press and hold the arrow to increase or decrease progressively faster. Press enter to save changes and move to the next input screen.

Continue this process until all four screens have been configured.

If you used the short-cut to enter Frequency Input setup, press and hold Mode button until Run Mode screen is displayed.

If you used the Menu button to navigate to Frequency Input setup, you must navigate back out of menu structure. To do this you must select <-Esc at bottom of every screen menu until you see Run Mode screen displayed.

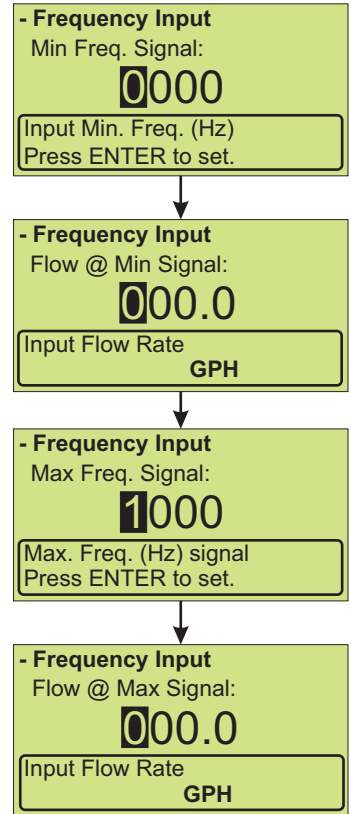

Examples:

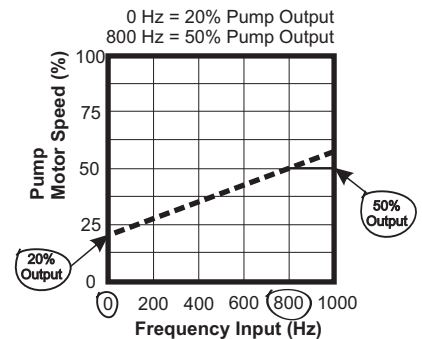
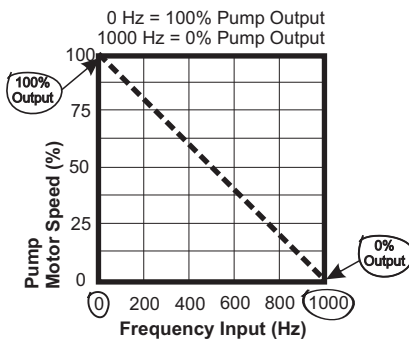
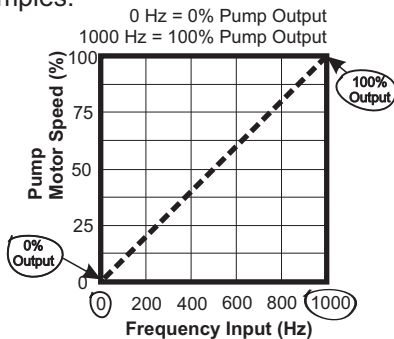

**Tip!**

When in the run mode, you can view the current pump output speed and input signal values by pressing the RIGHT arrow.

### 4.3.5 Pulse Batch (low speed pulse)

Used to remotely control the pump with an incoming pulse signal. Can be used with an external foot pedal, a water meter, a PLC, contact closure, or other low speed pulse devices.

Default settings: 1 Pulse = 100% motor speed for 2.5 seconds

Press MODE button until **Pulse Batch** is displayed in the top line of the display.

To configure the pump, navigate to **Pulse Batch** menu by using the short-cut method described at beginning of section, or by pressing MENU button, then selecting Input Setup, Input Modes, and then **Pulse Batch**.

Press UP or DOWN arrow to scroll through 0 - 9 on selected digit.

Press RIGHT arrow to scroll over to the next digit to the right. If you pass your desired digit, you can easily scroll back by continuously pressing the RIGHT button.

Press ENTER to save the changes.

Continue this process until all three screens have been configured.

If you used the short-cut to enter Pulse Batch setup, then just press and hold Mode button until the Run Mode screen is displayed.

If you used the Menu button to navigate to Pulse Batch setup, you must navigate back out of menu structure. To do this you must select <-Esc at bottom of every screen menu until you see Run Mode screen displayed.

- Pulse Batch  
Input Pulse Num:  
**0001**  
Pulse num. for batch  
Press ENTER to set.

- Pulse Batch  
% Motor Speed @ Batch:  
**100.0**  
Flow during batch.  
(use right arrow to select units)

- Pulse Batch  
Pump On Time:  
**00002.5**  
Run time for batch.  
Max = 999999.9 Seconds

#### Tip!



While operating in Pulse Batch mode, you can view the current incoming signal count by pressing the RIGHT arrow.

**Pulse Batch**  
Pulse Number: 0  
Run Time (SEC): 2.5

Displays current incoming signal

### 4.3.6 Manual Cycle Adjust (repeating cycle timer)

Used to operate the pump at a pre-selected motor speed for a specified run time. This cycle will repeat itself using a repeating cycle timer.

Default settings: 50% motor speed for 2.5 seconds  
Repeating cycle timer = 5.5 seconds

Press MODE button until **Manual Cycle Adjust** is displayed in the top line of the display.

To configure the pump, navigate to **Manual Cycle Adjustment** menu by using the short-cut method described at the beginning of the section, or by pressing MENU button, then selecting Input Setup, Input Modes, and then **Cycle Adjustment**.

Press UP or DOWN arrow to scroll through 0 - 9 on selected digit.

Press RIGHT arrow to scroll over to next digit to the right. If you pass your desired digit, you can easily scroll back by continuously pressing RIGHT button.

Press ENTER to save the changes.

Continue this process until all three screens have been configured.

If you used the short-cut to enter Manual Cycle Adjustment setup, press and hold Mode button until Run Mode screen is displayed.

If you used the Menu button to navigate to Cycle Adjustment setup, you must navigate back out of menu structure. To do this you must select <-Esc at bottom of every screen menu until you see Run Mode screen displayed.

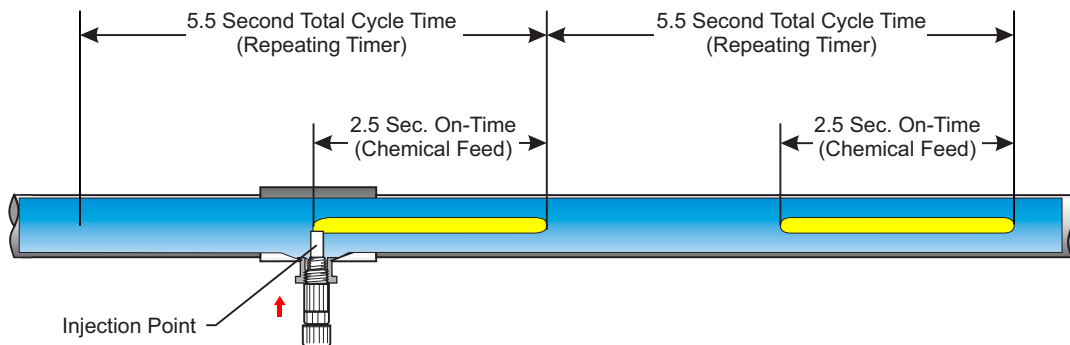
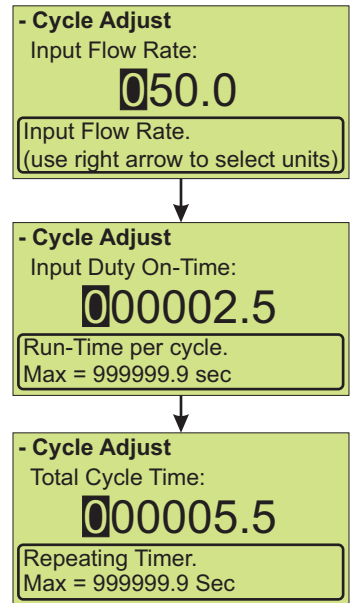

Graphical representation of Manual Cycle Adjust injection characteristics.

**Note:** Your chemical or solution is mixed in fluid. This image is only illustrating feed characteristics.

**Tip!**

While in Manual Cycle Adjust mode, you can view current settings by pressing the RIGHT arrow.

**Manual Cycle Adjust**

Cycle (SEC.): 5.5  
On Time (SEC.) 2.5

### 4.3.7 Dispensing

Configure any dispensing amount or sample size and the pump will repeat it on command by pressing the START button. Great for accurate single shot dispensing of a pre-configured volume.

Default settings:    10 milliliters  
                          100% pump speed

Press MODE button until **Dispensing** is displayed in the top line of the display.

To configure the pump, navigate to **Dispensing** menu by using the short-cut method described at beginning of the section, or by pressing MENU button, then selecting Input Setup, Input Modes, and then **Dispensing**.

Press UP or DOWN arrow to scroll through 0 - 9 on selected digit.

Press RIGHT arrow to scroll over to next digit to the right. If you pass your desired digit, you can easily scroll back by continuously pressing RIGHT button.

Press ENTER to save the changes.

Continue this process until two screens have been configured.

If you used the short-cut to enter Dispensing setup, press and hold Mode button until Run Mode screen is displayed.

If you used the Menu button to navigate to Dispensing setup, you must navigate back out of menu structure. To do this you must select <-Esc at bottom of every screen menu until you see Run Mode screen displayed.

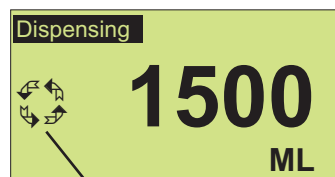
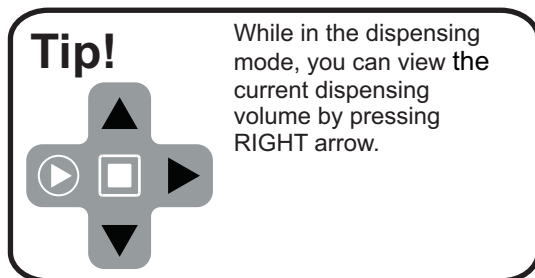
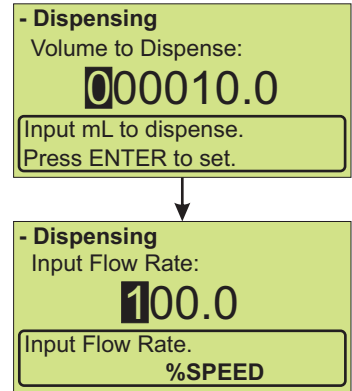

Displays motor run status

### 4.3.8 Manual Dosing

Used to configure Parts Per Million dosing to a system. This method can be used if treated fluid volume is a fixed amount (in Liters Per Minute). If treated fluid volume is variable (continuous change), then the use of a flow meter is recommended along with the Proportional Mode (next Run Mode).

Default settings:    12.5% dose solution concentration  
                           1.25 dose solution Specific Gravity  
                           10 LPM (liters per minute) fluid volume to be treated  
                           1.0 Parts Per Million to dose

Press MODE button until **Manual Dosing** is displayed in the top line of the display.

To configure the pump, navigate to **Manual Dosing** menu by using the short-cut method described at the beginning of the section, or by pressing MENU button, then selecting Input Setup, Input Modes, and then **Manual Dosing**.

Press UP or DOWN arrow to scroll through 0 - 9 on selected digit.

Press RIGHT arrow to scroll over to next digit to the right. If you pass your desired digit, you can easily scroll back by continuously pressing RIGHT button.

Press ENTER to save the changes.

Continue this process until all four screens have been configured.

If you used the short-cut to enter Manual Dosing setup, press and hold Mode button until Run Mode screen is displayed.

If you used the Menu button to navigate to Manual Dosing setup, you must navigate back out of menu structure. To do this you must select <-Esc at bottom of every screen menu until you see Run Mode screen displayed.

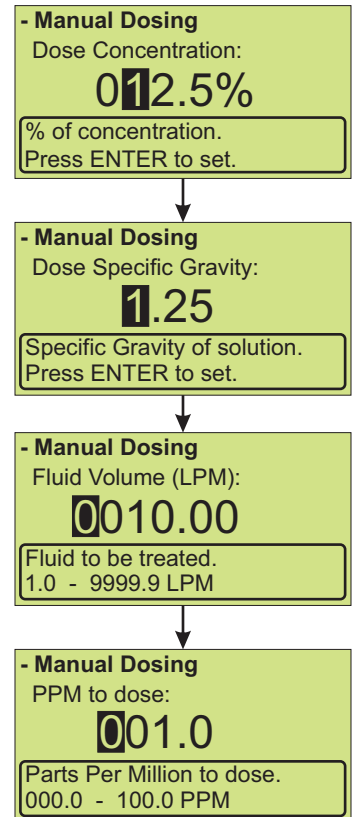

#### Tip!



While in the Manual Dosing mode, you can view the pump settings by pressing RIGHT arrow.

Manual Dosing	
% Concentration:	12.5
Spec. Gravity:	1.25

### 4.3.9 Proportional Dosing

Used to configure proportional Parts Per Million dosing to a system. This method of proportional dosing is based off an input signal the pump is receiving from an external flow meter. The flow meter must have a high speed pulse output >10Hz. You will need to refer to flow meter instruction manual to obtain the K-factor for the flow meter.

Default settings:    12.5% dose solution concentration  
                           1.25 dose solution Specific Gravity  
                           5.0 K-factor (Pulses Per Liter), see flow meter instruction manual  
                           1.0 Parts Per Million to dose

Press MODE button until **Proportional Dosing** is displayed in the top line of the display.

To configure the pump, navigate to **Proportional Dosing** menu by using the short-cut method described at the beginning of the section, or by pressing MENU button, then selecting Input Setup, Input Modes, and then **Proportional**.

Press UP or DOWN arrow to scroll through 0 - 9 on selected digit.

Press RIGHT arrow to scroll over to next digit to the right. If you pass your desired digit, you can easily scroll back by continuously pressing RIGHT button.

Press ENTER to save the changes.

Continue this process until all four screens have been configured.

If you used the short-cut to enter Proportional Dosing setup, press and hold Mode button until Run Mode screen is displayed.

If you used the Menu button to navigate to Proportional Dosing setup, you must navigate back out of menu structure. To do this you must select <-Esc at bottom of every screen menu until you see Run Mode screen displayed.

**- Proportional Dosing**  
Dose Concentration:  
**012.5%**  
Percentage of concentration.  
Press ENTER to set.

↓

**- Proportional Dosing**  
Dose Specific Gravity:  
**1.25**  
Specific Gravity of solution.  
Press ENTER to set.

↓

**- Proportional Dosing**  
Input K-Factor (pulses):  
**0005.0000**  
Pulses Per Liter.  
0.0001 - 9999.9999

↓

**- Proportional Dosing**  
PPM to dose:  
**001.0**  
Parts Per Million to dose.  
000.0 - 100.0 PPM

Example #1, Ultrasonic flow meter

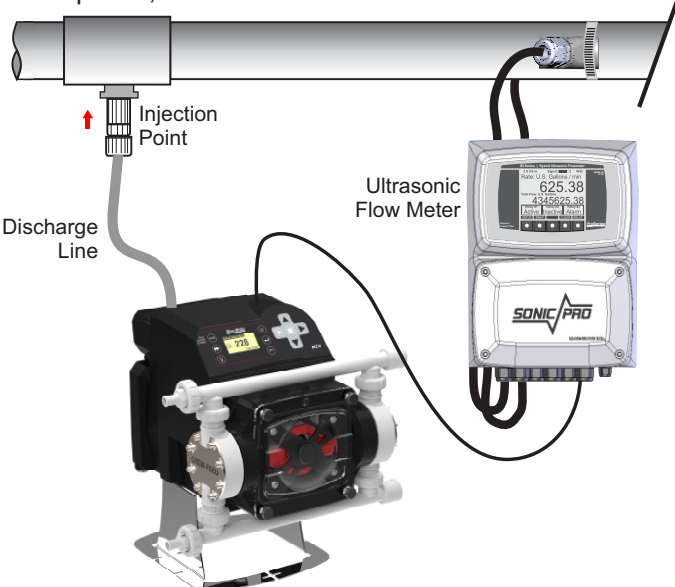

Example #2, Paddlewheel flow meter

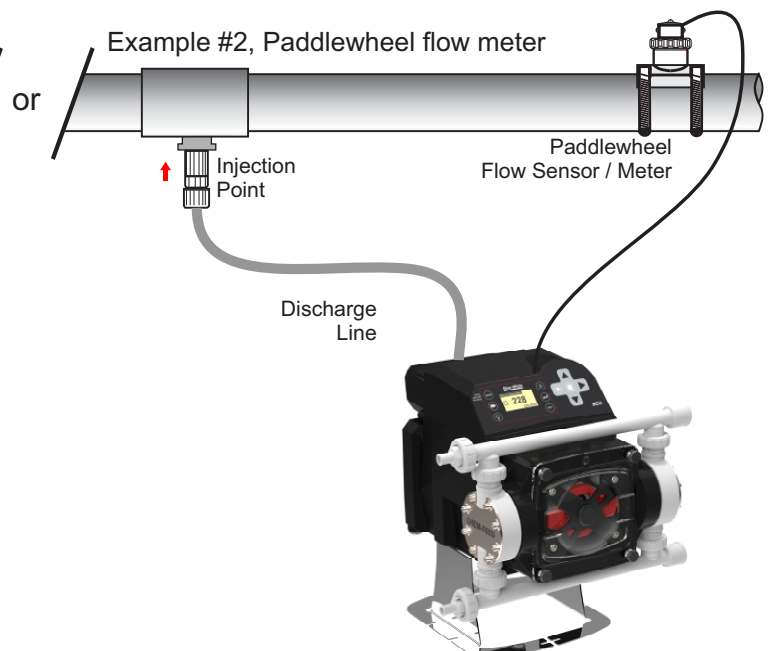



## 4.4 Contact Closure Input (Remote Start/Stop)

Used to remotely start and stop the pump using a close=stop or open=stop signal. If the pump must start when the loop is open, then select “Close: Stop Pump” option. Can be used with an external foot pedal, a PLC, contact closure, or other similar external devices.

Default settings: Disable

CC Input Range: 6 - 30 VDC  
**or**  
 Dry Contact Closure (no voltage required)  
 [See section 5.1 for wire connections]

Navigate to **Contact Input** menu by MENU button, then selecting Input Setup, and then **Contact Input**.

Press UP or DOWN arrow to scroll through your options.

Press ENTER to make a selection. You should then notice the radio button (square box) is now filled in next to your selection.

Press DOWN arrow to scroll down to Done selection. Then press ENTER.

To prevent false triggering due to flickering (high speed) electrical switches, a trigger delay time can be configured to delay the pump command. The delay time unit of measure is seconds. A two second delay time is recommended.

To navigate back out of menus, select <-Esc and press the ENTER button at the bottom of every screen menu until you see the Run Mode screen displayed.

**IMPORTANT:** To begin operation, press the START button to place pump in STANDBY. The display background will turn blue indicating the pump has been stopped remotely. When the pump is started by the remote contact, the display background will turn green.

**IMPORTANT:** If the Contact Closure Input is enabled, the pump will display STANDBY if the pump has been stopped by the Remote Contact Closure. **Please use caution in this mode as the pump may Start at anytime. If you must perform maintenance to the pump, Press STOP button.**

When Contact Closure Input is enabled, the word **Remote** will always be displayed on the lower left side of the display screen.

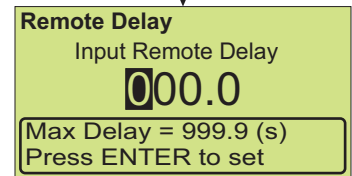
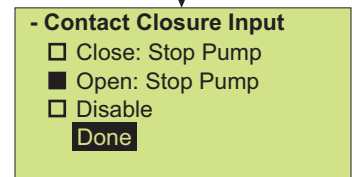
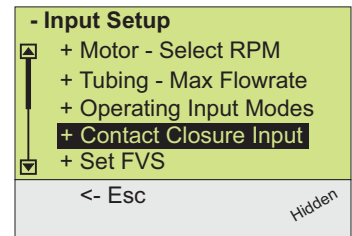
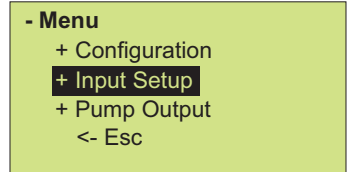

Signal stopped pump

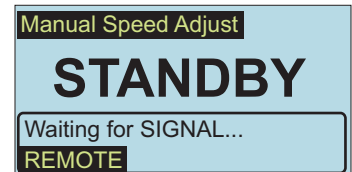

Signal started pump

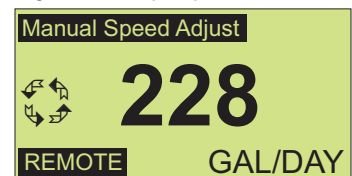

### 4.5 Set FVS (Flow Verification System)

Used to monitor the pump fluid output. If the pump does not dispense fluid when pump head rotor is turning, the pump will go into an alarm mode and stop. Blue-White offers a flow verification sensor that easily attaches to the outlet fitting of the pump.

Default settings: 000 (off)

Navigate to **Set FVS** menu by pressing MENU button, then selecting Input Setup, and then **Set FVS**.

Press UP or DOWN arrow to scroll through 0 - 9 on selected digit.

Press RIGHT arrow to scroll over to the next digit to right. If you pass your desired digit, you can easily scroll back by continuously pressing RIGHT button.

Press ENTER to save the changes and exit FVS screen.

To navigate back out of menus, select <-Esc and press ENTER button at the bottom of every screen menu until you see the Run Mode screen displayed.

Flow Verification Sensor is designed to give you two installation options.

Sensor can be installed:

- Directly onto pump head of MD3® pump, discharge side.
- Anywhere on discharge side of MD3® pump.

Wiring for sensor can be connected directly to a MD3® pump. Pump will stop pumping if sensor detects no flow. A relay will then close allowing for remote alarm indication or initiation of a back-up pump. **Install FVS Flow Sensor** - Flow Verification Sensor should be installed on discharge side of pump.

**Confirm FVS flow range** - Flow Verification Sensor (FVS) will only function within its operating range. See chart for available ranges.

NOTE: If pump output is less than 30 ml/min, sensor will not detect chemical and a signal will not be sent to pump, resulting in an alarm condition.

NOTE: For low viscosity (water-like) fluids only. Consult factory if attempting to use with viscous fluids.

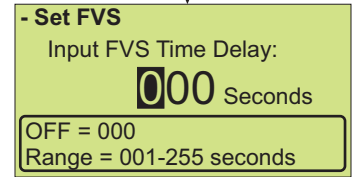
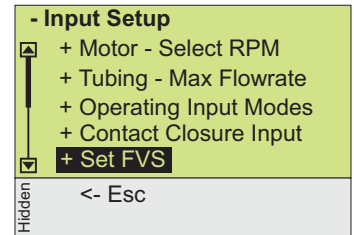

When a FVS alarm occurs



SENSOR MODEL NUMBER	PUBLISHED FLOW RANGE (ml/min)	ACTUAL WORKING RANGE WITH MD3 PUMP (ml/min)
FV-100	30-300	30-200
FV-200	100-1000	50-900
FV-300	200-2000	100-1800
FV-400	300-3000	300-3000
FV-500	500-5000	500-5000
FV-600	700-7000	700-7000



## 4.6 DFD (Diaphragm Failure Detection)

The MD3® is equipped with a Diaphragm Failure Detection System which is designed to stop pump and provide an output alarm in event diaphragm should rupture and chemical enters pump head. At the default adjustment setting of 75%, the pump will detect a chemical with a conductivity reading greater than 500 microsiemens. The system sensitivity can be increased to 100%, reducing the conductivity to 430 microsiemens. Chemicals with conductivity of less than 430 microsiemens will not be detected.

This system is capable of detecting presence of a large number of chemicals including Sodium Hypochlorite (Chlorine), Hydrochloric (muriatic) Acid, Sodium Hydroxide, and many others. System will not be triggered by water (rain, condensation, etc.) or lubricants.

If system has detected chemical, pump diaphragm must be replaced and pump head must be thoroughly cleaned. Failure to clean pump head will void warranty.

If DFD alarm occurs, pump will stop, close an alarm output, and screen will flash DFD with an alarm icon.

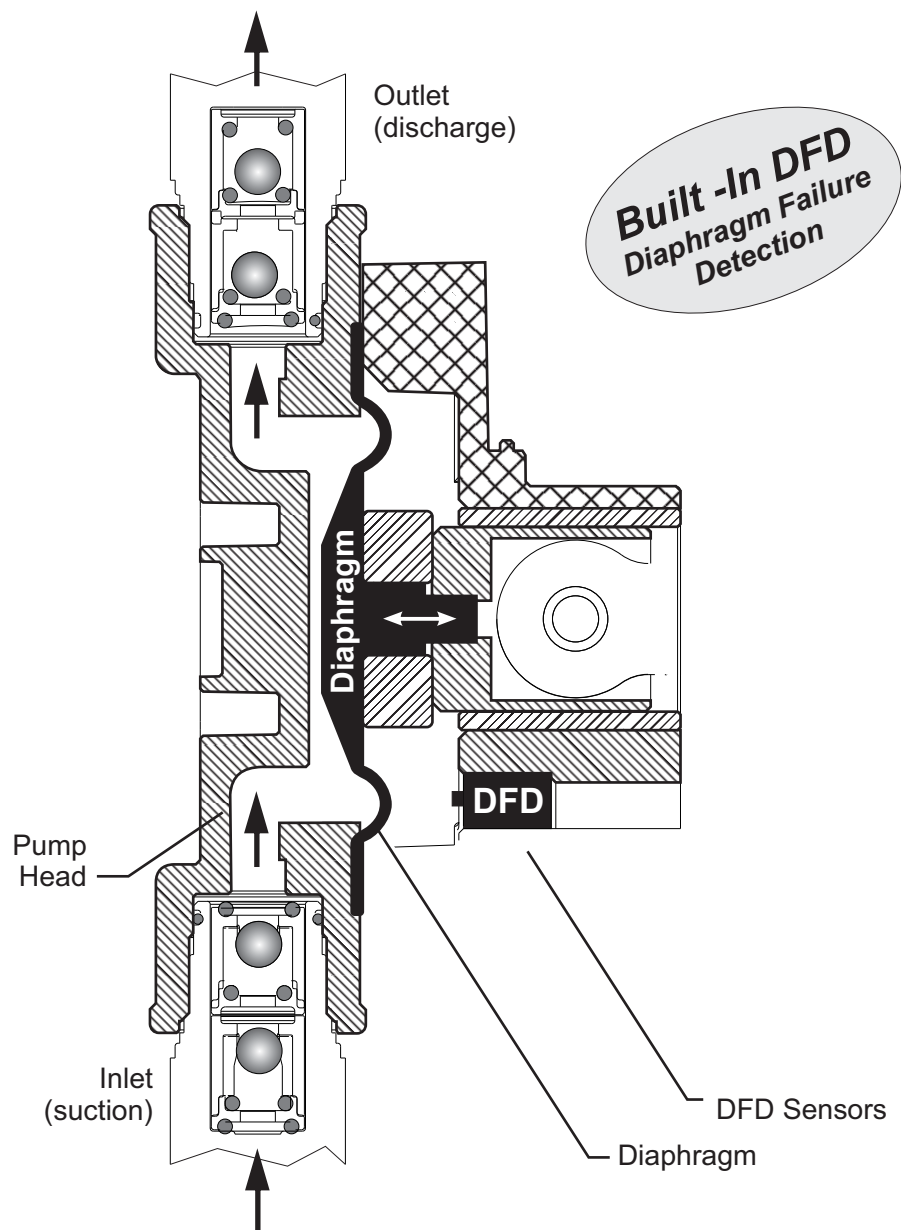

### 4.7 Remote/Local Control

The MD3 can be configured for Remote control only, Local control only, or either (disabled).

When set for Remote control only, all touch pad buttons except the menu button are disabled. To completely lock out the menu, configure a password (see page 12, section 8). If REMOTE ONLY is selected, the user is prompted to select an input operating mode which must then be used when operating the pump.

When set for local control only, all input signals including the remote start/stop are disabled. Note that the “contact closure input” menu setting (section 4.4) is switched to “disabled” while **LOCAL ONLY** is selected. This menu setting will return to the previous setting when **REMOTE ONLY** or **DISABLED** is selected.

**NOTE/CAUTION:** With certain firmware versions of this pump, the “contact closure input” may need to be **set again** to the desire setting “Close, Open, Disable” when activating **REMOTE ONLY**. **Always re-confirm “contact closure” setting when running in REMOTE ONLY.**

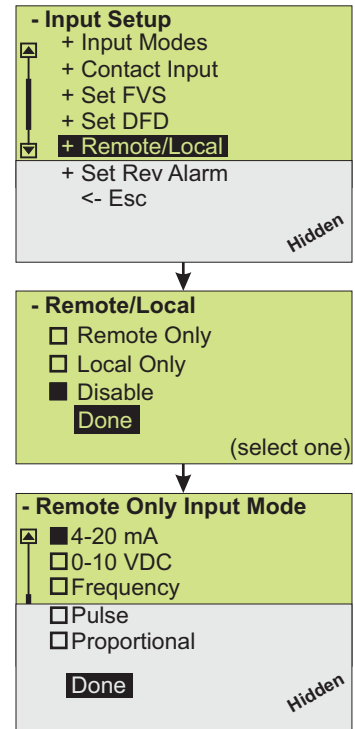

### 4.8 Set Revolution Alarm

The MD3 includes a revolution counter. A revolution alarm set point can be input which will alert the operator when a programmable number of revolutions has been reached.

When the set point is reached, the pump display will turn red and the words “REV ALARM” will be displayed. **The pump will not stop.**

An alarm output can be configured to close when the revolution set point is reached.

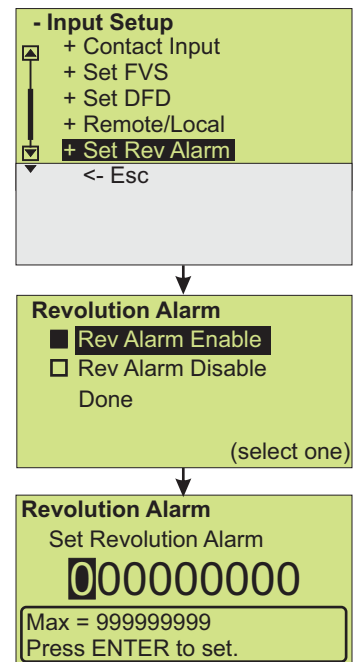

### 5.0 Output Setup (alarm relays)

Below is the menu structure for the Output Setup selection. The layout of the Output Setup menu is similar to the Input Setup menu. Outputs were designed to directly communicate to SCADA systems, alarms, data loggers, backup pumps, pumps to operate in sync, pumps to operate proportionally, and other external devices.

To prevent false alarms due to pump start-up and closed loop applications, a trigger delay time can be configured to delay the relay switch action. The delay time unit of measure is seconds.

### 5.0 Output Setup (alarm relays)

- Menu  
 + Configuration  
 + Input Setup  
**+ Output Setup**  
 + Power Fail option  
 <- Esc

**Note:**  
 Contact #1 shown only. Contact #2, and Contact #3 use the same menu items.

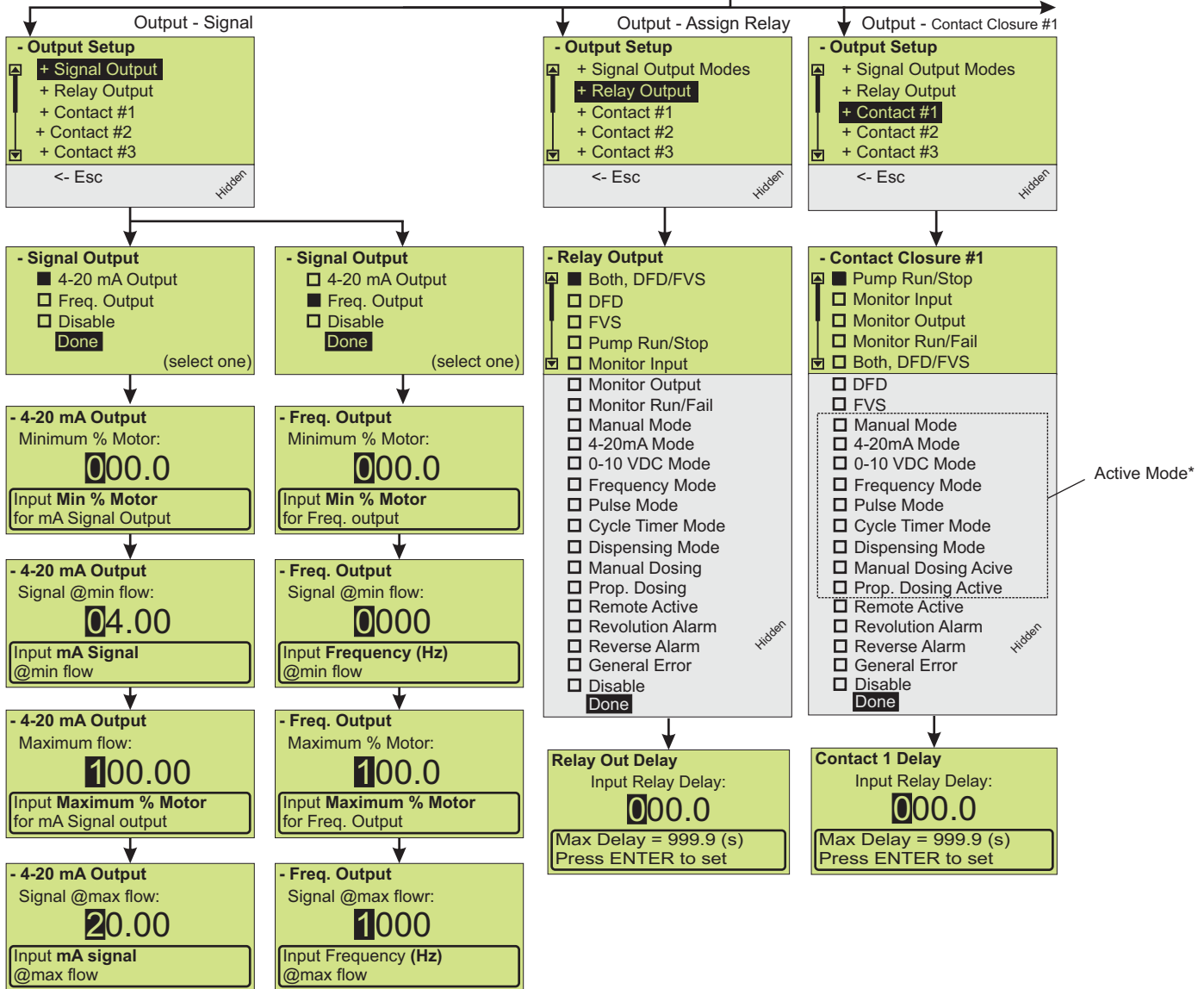

**Description of Relay and Contact Closure Output triggers**

**Selection:**                      **Contact energizes when:**

*Pump Run/Stop* .....Motor turning.

*Monitor Input* .....Incoming analog or digital signal is not received or out of range.

*Monitor Output*.....Outgoing analog or digital signal not transmitted or out of range.

*Monitor Run/Fail*.....Motor fails to respond to commands.

*Both DFD/FVS*.....Either DFD or FVS system triggers.

*FVS* .....After the programmed delay time, pulses are not received from flow sensor.

*DFD* .....Diaphragm failure is detected by sensors.

*Active Mode*.....Use to monitor any changes to the active (run) mode selection.\*

*Remote Active* .....Energized when Remote only is active.

*Revolution Alarm*.....Revolution count set-point has been achieved.

*General Error*.....A motor overload or other internal error has occurred (includes DFD/FVS).

*Disable*.....Output contact is disabled.

## 5.1 Signal Output

Sends a configurable 4 - 20 mA or frequency (Hz) signal to another pump or external device. This feature can be used to control other pumps (in sync / proportionally), data logging systems, and other external devices for plant automation.

Default settings: Disable

Navigate to **Signal Output** menu by pressing MENU button, then selecting Output Setup, and then **Signal Output**.

Select your desired Signal output using UP or DOWN arrows.

Press ENTER to configure the output signal.

Press UP or DOWN arrow to scroll through 0 - 9 on selected digit.

Press RIGHT arrow to scroll over to the next digit to the right. If you pass your desired digit, you can easily scroll back by continuously pressing RIGHT button.

Press ENTER to save the changes.

Continue this process until all four screens have been configured.

To navigate back out of the menu structure you must select <-Esc at bottom of every screen menu until you see Run Mode screen displayed.

Example 1

0% Pump Output = 4 mA  
100 % Pump Output = 20 mA

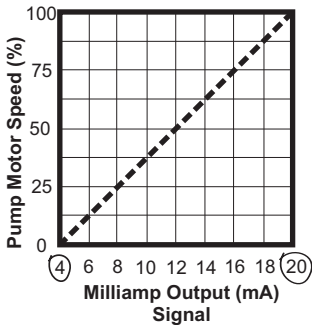

Example 2

0% Pump Output = 4 mA  
50% Pump Output = 16 mA

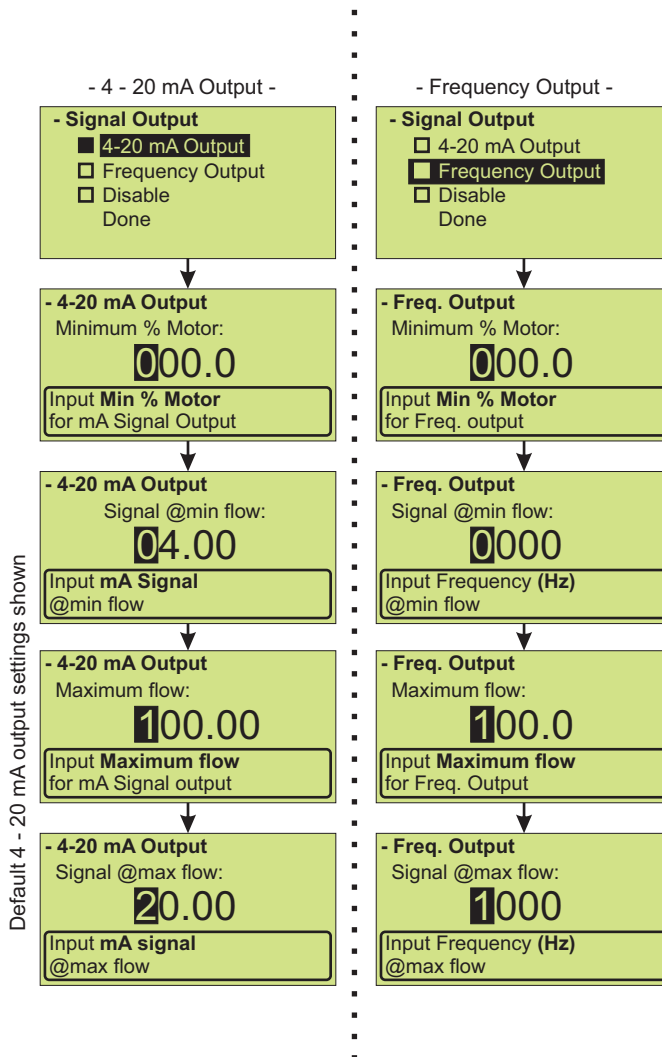
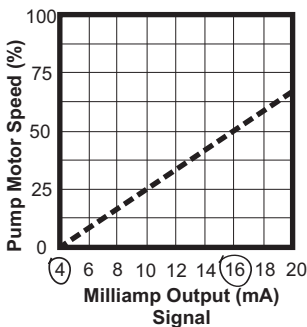

Example 1

0% Pump Output = 0 Hz  
100 % Pump Output = 1000 Hz

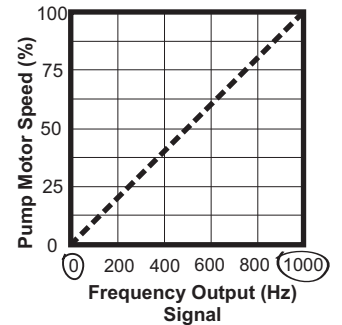

Example 2

0% Pump Output = 1000 Hz  
100% Pump Output = 0 Hz

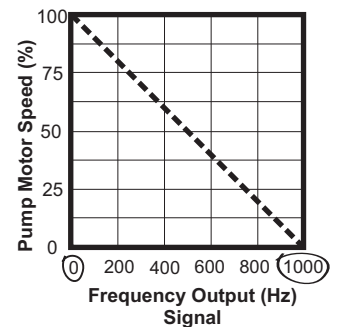

## 6.0 Pump Maintenance

### CAUTION



Prior to service, pump clean water through pump and suction / discharge line to remove chemical.

### CAUTION



Always wear protective clothing, face shield, safety glasses and gloves when working on or near your metering pump. Additional precautions should be taken depending on solution being pumped. Refer to MSDS precautions from your solution supplier.

## 6.1 Routine Inspection and Maintenance

Pump requires very little maintenance. However, pump and all accessories should be checked weekly. This is especially important when pumping chemicals. Inspect all components for signs of leaking, swelling, cracking, discoloration or corrosion. Replace worn or damaged components immediately.

Cracking, crazing, discoloration during first week of operation are signs of severe chemical attack. If this occurs, immediately remove chemical from pump. Determine which parts are being attacked and replace them with parts that have been manufactured using more suitable materials. Manufacturer does not assume responsibility for damage to pump that has been caused by chemical attack.

## 6.2 Cleaning Pump

Pump will require occasional cleaning, especially Injection fitting, Footvalve / Strainer, and pump head valves. Frequency will depend on type and severity of service.

- ☑ Inspect and replace pump head valves as required.
- ☑ Periodically clean injection / check valve assembly, especially when injecting fluids that calcify such as sodium hypochlorite. These lime deposits and other build ups can clog fitting, increase back pressure and interfere with check valve operation.
- ☑ Periodically clean suction strainer.
- ☑ Periodically inspect pump housing (enclosure) for chemical attack. Protect pump housing from continuous exposure to chemicals, such as drips or fumes from surrounding equipment and plumbing.

## 6.3 Replacing the Pump Diaphragm

- ☑ When changing the diaphragm, the pump head chamber and pump head cover should be wiped free of any dirt and debris. The pump stroke must be FORWARD when installing the diaphragm, and BACK when installing and tightening the pump head.
- ☑ When replacing the pump diaphragm, note the order of parts per the illustration below:
- ☑ Tighten pump head bolts in star-shaped pattern, so as to not overtighten one side. Tighten bolts to 38 in-lbs. **(Note: Check bolts and torque after 1-2 hours, as material may soften after initial break-in period. )**

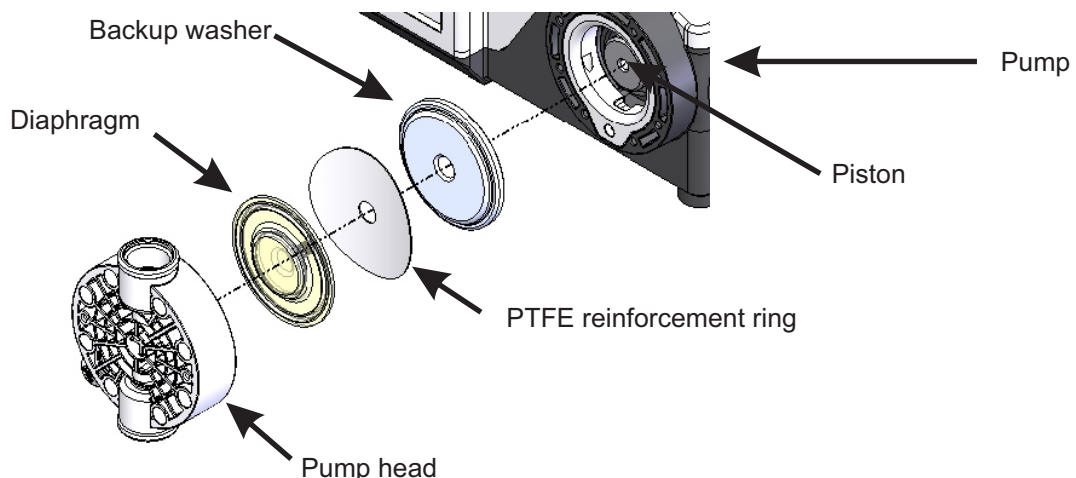

### 7.0 Exploded view and parts list

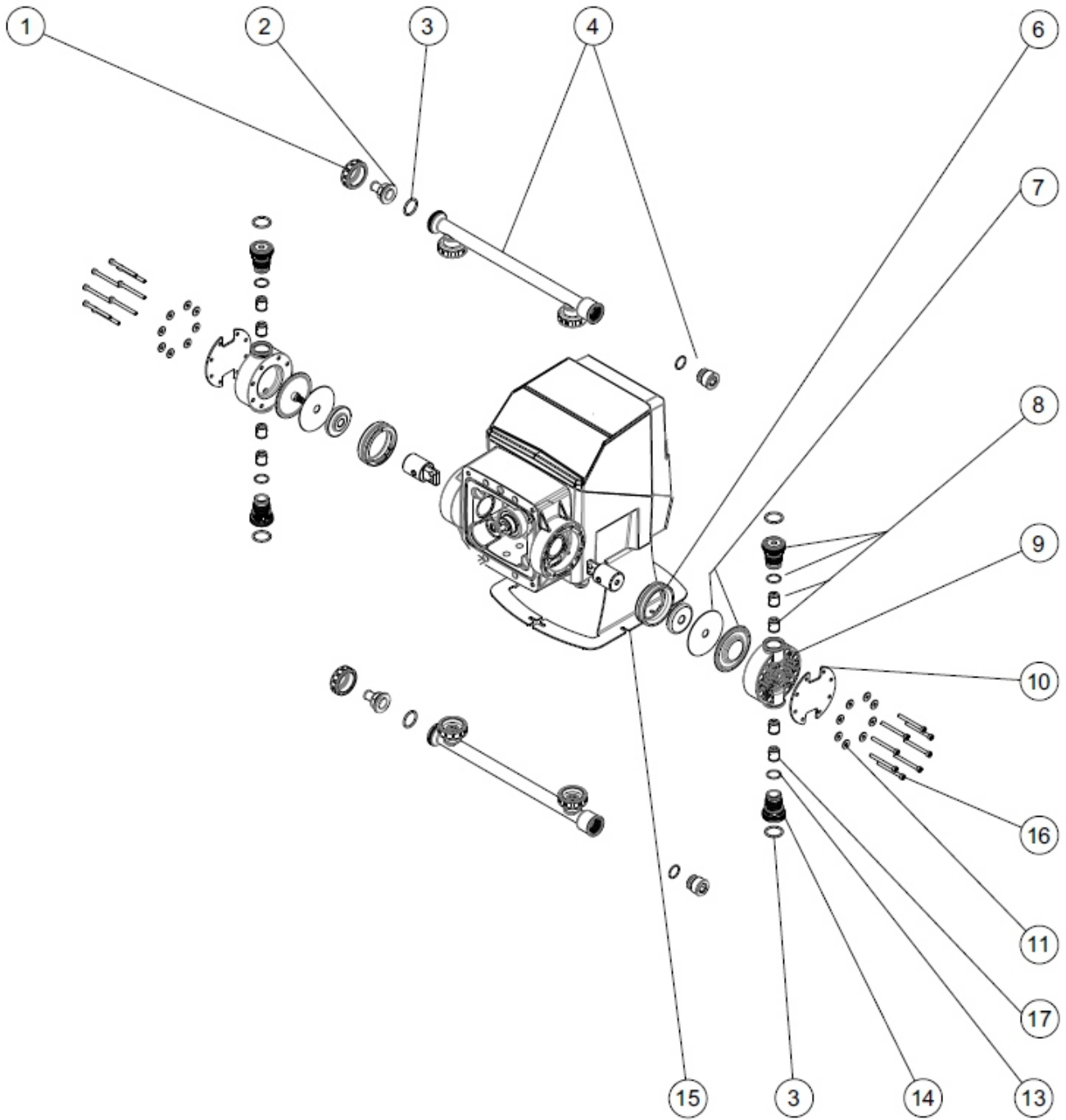



## 7.0 (continued)

ITEM NO.	PART NUMBER	DESCRIPTION	QTY.
1	91001-301	NUT UNION MD3 MOLDED PVDF	6
2	91001-295	.50" BARB ADAPTER	2
	91001-296	.50" BARB ADAPTER ELBOW	
	91001-288	.50" M/NPT ADAPTER ELBOW	
	91001-287	.50" M/NPT ADAPTER	
3	90003-577	O-RING 2-119 (AFLAS 75)	6
	90003-627	O-RING 2-119 (EP)	
4	70001-504	MANIFOLD WITH FLANGE AND UNION NUT, PLUG WITH O-RING (TFE/P)	2
	70001-505	MANIFOLD WITH FLANGE AND UNION NUT, PLUG WITH O-RING (EP)	2
6	90002-350	DRIVE HEAD INSERT	2
7	72000-583	KIT DIAPHRAGM PVDF MD3	2
	72000-601	KIT DIAPHRAGM FLEX-A-PRENE® MD3	
8	70001-500	CARTRIDGE VALVE KIT (TFE/P)	4
	70001-501	CARTRIDGE VALVE KIT (EP)	
9	90002-272	PUMP HEAD	2
10	70004-541	PUMP HEAD FACE PLATE	2
11	90011-094	WASHER #10	16
12	90011-063	SCREW 8-32 X .37 RD PH SS	4
13	90003-141	O-RING 2-018 (TFE/P)	4
	90003-610	O-RING 2-018 (EP)	
14	90002-353	ADAPTER CART MD3	4
15	90008-651	MOUNTING BRACKET	2
16	90011-210	SCREW 10-32 X 2.0 SOC HD	16
17	20000-226	Kit (8) Ball Check Cart., Aflas	1
17	20000-227	Kit (8) Ball Check Cart., EP	1
17	20000-229	Kit (4) Ball Check Cart., Aflas, PTFE Balls	2

### 8.0 Output versus pressure

## MD3 Hybrid Metering Pump

100% Speed = 190 RPM (380 Strokes Per Minute)

Motor Speed (%)	Feed Rate at 0 PSig			Feed Rate at 40 PSig			Feed Rate at 90 PSig			Feed Rate at 140 PSig		
	RPM	ML/MIN	GPH	RPM	ML/MIN	GPH	RPM	ML/MIN	GPH	RPM	ML/MIN	GPH
1	1.3	32	0.5	1.3	32	0.5	1.3	25	0.4	1.3	25	0.4
5	10	164	2.6	10	151	2.4	10	145	2.3	10	132	2.1
10	19	315	5.0	19	303	4.8	19	278	4.4	19	259	4.1
25	48	789	12.5	48	751	11.9	48	694	11.0	48	681	10.8
50	95	1577	25.0	95	1508	23.9	95	1388	22.0	95	1350	21.4
75	142	2372	37.6	142	2252	35.7	142	2107	33.4	142	1968	31.2
100	190	3318	52.6	190	3041	48.2	190	2391	37.9	190	2182	34.6

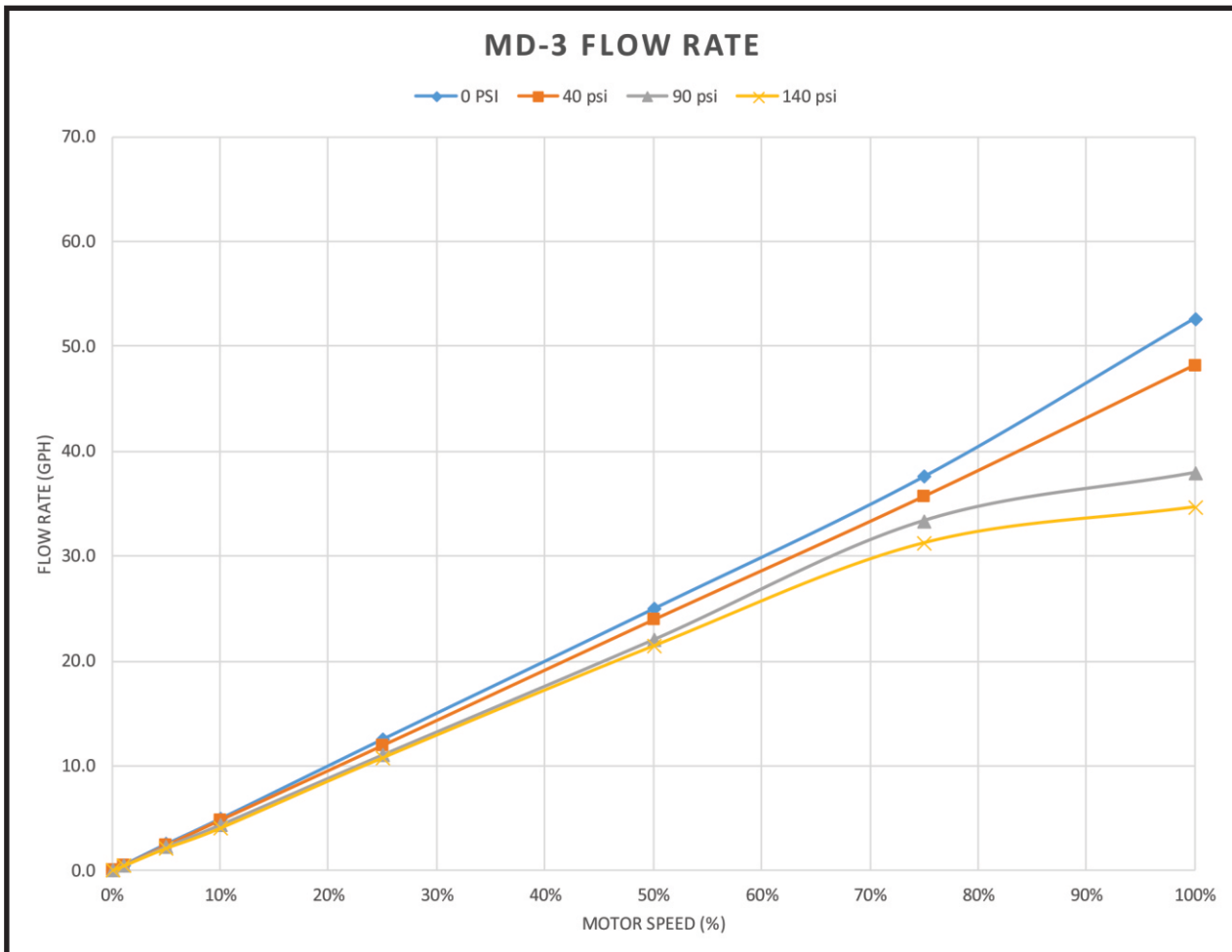

Page intentionally left blank

Page intentionally left blank

Page intentionally left blank

## 9.0 WARRANTY

### 9.1 Limited Warranty

Your Blue-White product is a quality product and is warranted for a specific time from date of purchase (proof of purchase is required). The product will be repaired or replaced at our discretion. Failure must have occurred due to defect in material or workmanship and not as a result of operation of the product other than in normal operation as defined in the product manual. Warranty status is determined by the product's serial label and the sales invoice or receipt. The serial label must be on the product and legible. The warranty status of the product will be verified by Blue-White or a factory authorized service center.

CHEM-FEED® MD3 pumps are warranted for 5 years from date of purchase (proof of purchase is required). Pumps will be repaired or replaced at our discretion.

### 9.2 DIAFLEX® Warranty

DIAFLEX® diaphragms are warranted for the life of the pump. Blue-White will replace a damaged diaphragm at no cost to the customer provided the pump was at all times operated within the guidelines included in the pump's operation manual. This warranty only applies to DIAFLEX® diaphragms, not the pumps themselves. Blue-White pumps are separately covered by warranties specific to them.

### 9.3 What is not Covered

- > **Flex-A-Prene diaphragm and rubber components - They are perishable and require periodic replacement**
- > **Pump removal, or re-installation, and any related labor charge.**
- > **Freight to the factory, or service center**
- > **Pumps that have been tampered with, or in pieces.**
- > **Damage to the pump that results from misuse, carelessness (such as chemical spills on the enclosure), abuse, lack of maintenance, or alteration that is out of Blue-White control.**
- > **Pumps damaged by faulty wiring, power surges, or acts of nature.**

Blue-White does not assume responsibility for any loss, damage, or expense directly or indirectly related to or arising out of the use of its products. Failure must have occurred due to defect in material or workmanship and not as a result of operation of the product other than in normal operation as defined in the pump operation manual.

The warranty status is determined by the pump's serial label and the sales invoice or receipt. The serial label must be on the pump and be legible. The warranty status of the pump will be verified by Blue-White or a factory authorized service center.

### 9.4 Procedure for In-Warranty Repair

Warranty service must be performed by the factory or an authorized service center. Contact the factory or local repair center to obtain a RMA (Return Material Authorization) number. It is recommended to include foot strainer and injection/check valve fitting since these devices may be clogged and part of the problem. Decontaminate, dry, and carefully pack the product to be repaired. Please enclose a brief description of the problem and proof of purchase. Prepay all shipping and insurance cost. COD shipments will not be accepted. Damage caused by improper packaging is the responsibility of the sender. When In-Warranty repair is completed, the factory pays for return shipping to the dealer or customer.

### 9.5 Product Use Warning

Blue-White products are manufactured to meet the highest quality standards in the industry. Each product instruction manual includes a description of the associated product warranty and provides the user with important safety information. Purchasers, installers, and operators of Blue-White products should take the time to inform themselves about the safe operation of these products. In addition, Customers are expected to do their own due diligence regarding which products and materials are best suited for their intended applications. Blue-White is pleased to assist in this effort but does not guarantee the suitability of any particular product for any specific application as Blue-White does not have the same degree of familiarity with the application that the customer/end user has. While Blue-White will honor all of its product warranties according to their terms and conditions, Blue-White shall only be obligated to repair or replace its defective parts or products in accordance with the associated product warranties. **BLUE-WHITE SHALL NOT BE LIABLE EITHER IN TORT OR IN CONTRACT FOR ANY LOSS OR DAMAGE WHETHER DIRECT, INDIRECT, INCIDENTAL, OR CONSEQUENTIAL, ARISING OUT OF OR RELATED TO THE FAILURE OF ANY OF ITS PARTS OR PRODUCTS OR OF THEIR UNSUITABILITY FOR A GIVEN PURPOSE OR APPLICATION.**

### 9.6 Chemical Resistance Warning

Blue-White offers a wide variety of wetted parts. Purchasers, installers, and operators of Blue-White products must be well informed and aware of the precautions to be taken when injecting or measuring various chemicals, especially those considered to be irritants, contaminants or hazardous. Customers are expected to do their own due diligence regarding which products and materials are best suited for their applications, particularly as it may relate to the potential effects of certain chemicals on Blue-White products and the potential for adverse chemical interactions.

Blue-White tests its products with water only. The chemical resistance information included in this instruction manual was supplied to Blue-White by reputable sources, but Blue-White is not able to vouch for the accuracy or completeness thereof. While Blue-White will honor all of its product warranties according to their terms and conditions, Blue-White shall only be obligated to repair or replace its defective parts or products in accordance with the associated product warranties.

**BLUE-WHITE SHALL NOT BE LIABLE EITHER IN TORT OR IN CONTRACT FOR ANY LOSS OR DAMAGE, WHETHER DIRECT, INDIRECT, INCIDENTAL, OR CONSEQUENTIAL, ARISING OUT OF OR RELATED TO THE USE OF CHEMICALS IN CONNECTION WITH ANY BLUE-WHITE PRODUCTS.**

# Model Number Matrix

MD3

## CHEM-FEED® Model Number

<b>MD3</b>	CHEM-FEED® Multi-Diaphragm Metering Pump							
<b>Input Voltage / Power Cord</b>								
<b>4</b>	115V / 60Hz, power cord NEMA 5/15 plug (US)							
<b>5</b>	230V / 60Hz, power cord NEMA 6/15 plug (US)							
<b>6</b>	220V / 50HZ, power cord CEE 7/VII plug (EU)							
<b>8</b>	240V / 50HZ, power cord AS 3112 plug (Australia/New Zealand)							
<b>9</b>	230V / 50HZ, power cord BS 1363/A plug (United Kingdom)							
<b>X</b>	No Power Cord							
<b>Elastomer Material (O-Rings)</b>								
<b>V</b>	TFE/P							
<b>E</b>	EP							
<b>Diaphragm Type</b>								
<b>(blank)</b>	Standard							
<b>S</b>	Flex-A-Prene® Diaphragms (Caustic Soda resistant diaphragms)							
<b>Check Balls</b>								
<b>(blank)</b>	Standard							
<b>H</b>	PTFE balls (double ball check valves) low viscosity/density fluids only							
<b>MD3</b>	<b>2</b>	<b>4</b>	<b>4</b>	<b>X</b>	<b>V</b>	<b>X</b>	<b>-</b>	<b>Sample Model Number</b>

## Accessories



**KIT-PSM**  
Wall Mount Bracket, HDPE



**71000-579**  
PVDF INJECTOR, 1/2" Hose Barb  
**71000-577**  
PVDF INJECTOR, 1/2" MNPT



**76001-361**  
Suction Tubing, Clear PVC, 1/2" ID, 8ft  
**90008-437**  
Discharge Tubing, Braided PVC, 1/2" ID

**Ball Check Cartridge Options**

**20000-229 (2 req.)**  
Ball Check Cart. PTFE Balls

**20000-228 (2 req.)**  
Ball Check Cart. Hastelloy Balls

**70001-409 (4 req.)**  
Ball Check Cart., Single Ceramic Ball with Hastelloy Spring

Visit Accessory Pages for More Options

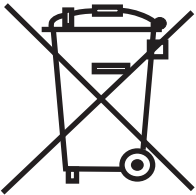

Users of electrical and electronic equipment (EEE) with the WEEE marking per Annex IV of the WEEE Directive must not dispose of end of life EEE as unsorted municipal waste, but use the collection framework available to them for the return, recycle, recovery of WEEE and minimize any potential effects of EEE on the environment and human health due to the presence of hazardous substances. The WEEE marking applies only to countries within the European Union (EU) and Norway. Appliances are labeled in accordance with European Directive 2002/96/EC.

Contact your local waste recovery agency for a *Designated Collection Facility* in your area.

**Blue-White**<sup>®</sup>

5300 Business Drive  
Huntington Beach, CA 92649  
USA

TEL: 714-893-8529  
FAX: 714-894-9492

[www.blue-white.com](http://www.blue-white.com)  
[sales@blue-white.com](mailto:sales@blue-white.com)  
[customerservice@blue-white.com](mailto:customerservice@blue-white.com)