

CFWS-2

CHEM-FEED® Wall Mount Duplex Skid System



Features

- > Chemically resistant polyethylene structure
- > Leak free, threadless connections
- > Pressure Relief Valve protects the system from over-pressurization
- > Check Valve protects the user from back-flow
- > Optional Flow Sensor for monitoring chemical flow
- > Included handles for easy installation

Video link: 

Highlights

Piping

PVC Schedule 80
(optional CPVC, PVDF,
and CHEM PROLINE®)

Pressure

150 PSI
(10.3 bar)

Compatibility

A1, A2, A3, A4,
CD1, C2, C3, CD3

Frame material

Polyethylene

Mounting position

Wall

Warranty

2 Years



Skid	Chemically resistant polyethylene structure
Pump (sold separately)	FLEXFLO® A1, A2, A3 or A4 peristaltic pumps CHEM-FEED® CD1, C2, C3 or CD3 diaphragm pumps
Piping	1/2" PVC Schedule 80 (optional CPVC, PVDF, CHEM PROLINE®)
Seals	FKM seals (optional EPDM)
Tubing (T)	Reinforced braided PVC, 200 psi max, certified NSF 51 / NSF 61. The pump inlet and outlet flexible tubing connections are terminated to half unions and secured to the barbed fitting with stainless steel clamps. (Optional: 1/2" PTFE, 1/4" PE, 1/4" PTFE)
Tubing Clamps	300 series SS band, 400 series SS screw
Unions (U)	PVC body, schedule 80 (optional CPVC, PVDF)
Ball Valves (V)	True unions, PVC body, PTFE shaft bearings and seats (optional CPVC, PVDF)
Pressure Relief Valve (PRV)	PVC body, PTFE primary diaphragm seal. Non-wetted components: EPDM secondary seal, zinc plated steel spring, stainless steel external hardware, HDPE pressure adjustment screw. Infinite adjustment from 10-150 psi. (optional CPVC, PVDF)
Calibration Cylinder (CC)	PVC body, PVC end caps, 1/2" PVC pipe outlet vent. Available volumes: 3 GPH (100ml), 8 GPH (250ml), 16 GPH (500ml), 32 GPH (1000ml), 64 GPH (2000ml), and 128 GPH (4000ml). (Optional Glass)
Pulsation Dampener (PD)	CPVC body, 10 cubic inch volume (optional PVDF)
Gauge W/Guard (G)	Gauge: liquid filled stainless steel with blowout plug, bottom mount, 1/4" NPT threads. Available pressure ranges: 0-30 psi, 0-100, psi, 0-200 psi. Guard: PVC body, temperature compensated oil filled. (optional CPVC, PVDF)
Check Valve (CV)	PVC body. Cracking pressure: 1.0-1.5 psi Maximum working pressure: inlet = 150 psi, back = 100 psi (optional CPVC, PVDF)
Flow Sensor (S6A)	Available Flow Ranges: 10 - 5,000 ml/min, 100 - 10,000 ml/min
Y Strainer (S)	PVC body, 1/32" Mesh (optional CPVC, PVDF)
Pressure Switch (PSH)	316 Stainless Steel
Back-Pressure Valve (BPV)	PVC body, 0-150 PSI Range (optional CPVC, PVDF)
Universal Mounting Blocks	PA 12
Pump Mounting Brackets	316 Stainless Steel
Skid Mounting Strut	FRP
Mounting Hardware	304 Stainless Steel
Maximum Working Pressure	150 psig (10.3 bar)
Operating Temperature	14 °F to 115 °F (-10 °C to 46 °C)
Maximum Overall Dimensions	60" W x 48" H x 17.41" D (152.4W x 121.9H x 44.2D cm)
Skid Weight	80 lb. (Not including pumps)
Approximate Shipping Weight	280 lb. (127 kg) (Pumps ship separately)
Approximate Shipping Dimensions	17" x 50" x 62" (Pumps ship separately)

Piping and Instrumentation Diagrams

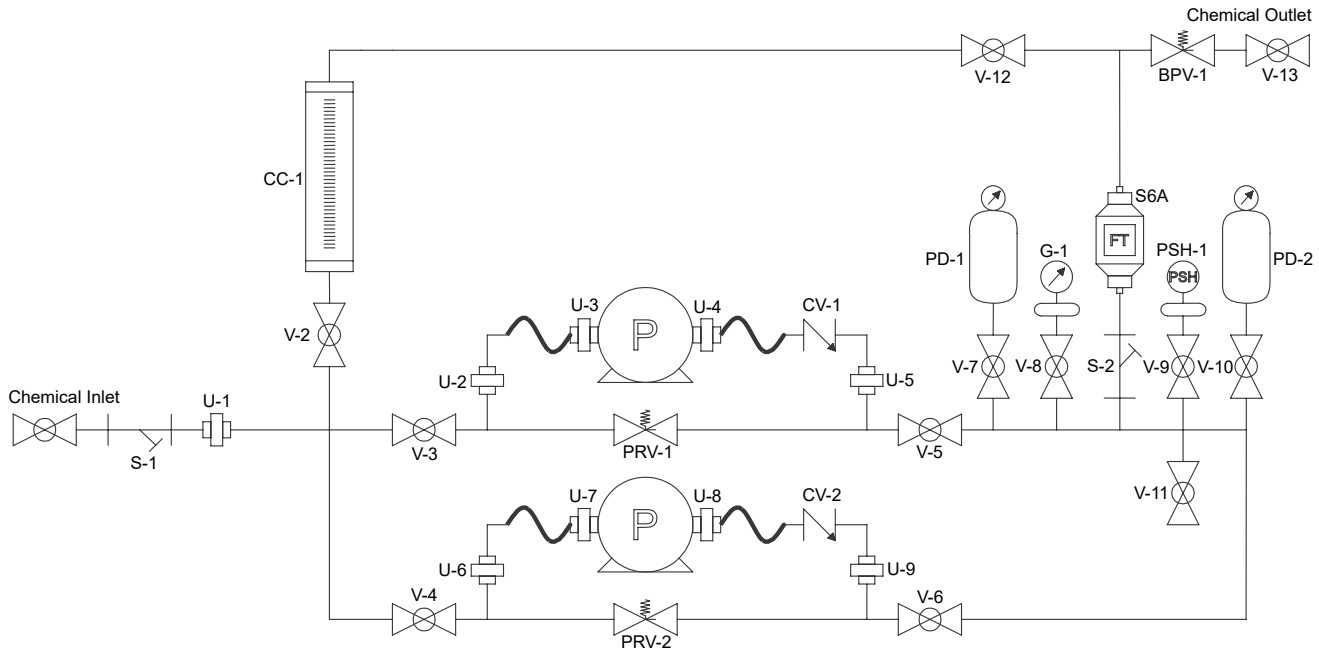

Dimensions

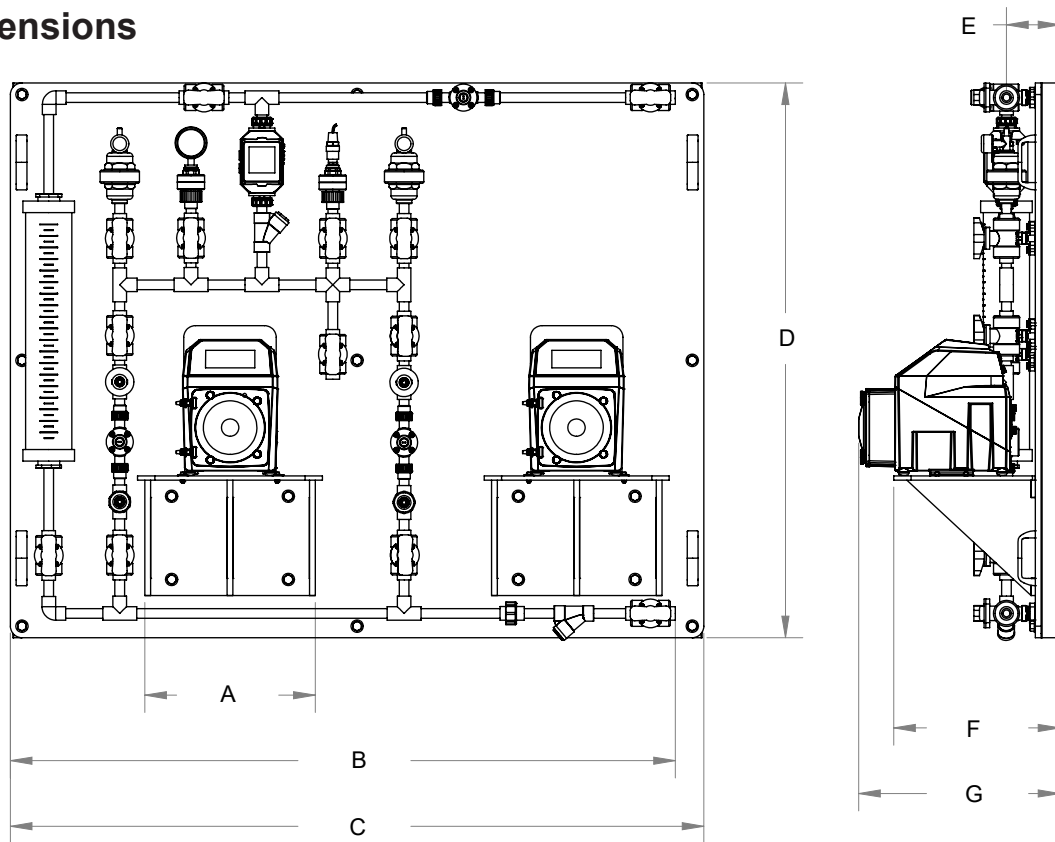

Dim	Inch	cm	Dim	Inch	cm
A	14.75"	37.5	E	4.63"	117.0
B	57.53"	146.1	F	14.38"	36.5
C	60.00"	152.4	G	17.41"	44.2
D	48.00"	121.9			

Model Number Matrix

CFWS-2

CHEM-FEED® Duplex Wall Skid System Matrix - Industrial

CFWS-2 Duplex pump system - single chemical / single outlet, PE structure

Inlet/Outlet

A	Single Inlet / Single Outlet
X	None, Skid Panel Only

Piping/Unions

A	PVC	C	PVDF
B	CPVC	D	CHEM PROLINE®

Seals

V	FKM	E	EPDM
----------	-----	----------	------

Tubing Connections

A	1/2" ID PVC Braided	C	1/4" ID PE
B	1/2" ID PTFE	D	1/4" ID PTFE

Calibration Column

A	128 GPH (4000 ml) PVC	F	3 GPH (100 ml) PVC
B	64 GPH (2000 ml) PVC	P	32 GPH (1000 ml) Glass
C	32 GPH (1000 ml) PVC	Q	16 GPH (500 ml) Glass
D	16 GPH (500 ml) PVC	R	8 GPH (250 ml) Glass
E	8 GPH (250 ml) PVC	S	3 GPH (100 ml) Glass

Pulsation Dampener* (10 cubic in.)

P	Two Dampeners	D	One Dampener	X	Not Included
----------	---------------	----------	--------------	----------	--------------

Back Pressure Valve

B	Included	X	Not Included
----------	----------	----------	--------------

Pressure Gauge w/Guard

A	200 PSI	B	100 PSI	C	30 PSI
----------	---------	----------	---------	----------	--------

Pressure Switch w/Guard

S	Included	X	Not Included
----------	----------	----------	--------------

Flow Meter w/Strainer

A	10-5000 mL/min
B	100-10000 mL/min
X	Not Included

CFWS-2 **I** **A** **A** **V** **A** **A** **P** **B** **A** **S** **A** **X** **X** **Sample Model Number**

NOTES: When ordering pumps for skids, pump head orientation is standard LEFT facing only. Terminal Boxes quoted and mounted separately. All skids are pressure tested prior to shipment. Pumps are purchased and shipped separately. Contact factory for quote/pricing on 5-point performance testing. **Reference Adapter Kits Sheet 85000-198 when ordering with pumps utilizing "M = 1/2"MNPT" or "F = 1/2"FNPT" connections.**

P.N. #85000-181 CFWS-2 REV 5 20240227

5300 Business Drive, Huntington Beach, CA 92649
 TEL 714-893-8529 | FAX 714-894-9492 | www.blue-white.com | sales@blue-white.com

